

# CONVEYING SYSTEMS

---

Effective and innovative  
**materials conveying  
and controls.**

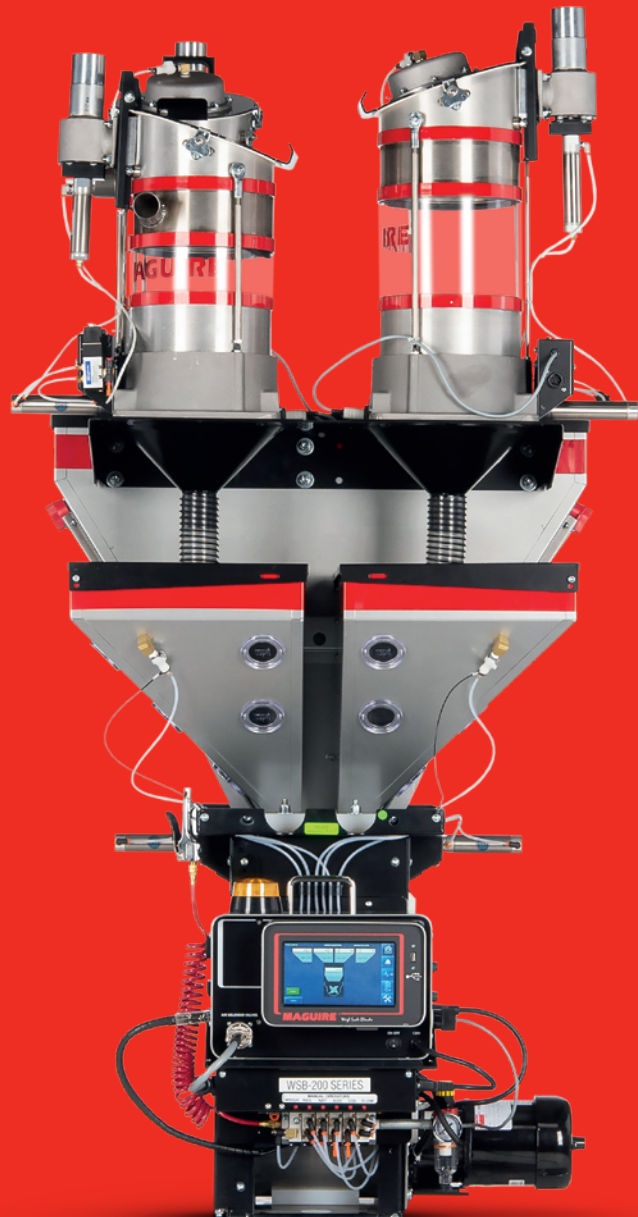

**PRODUCT GUIDE**

# Maguire Loading System: ML Series Venturi Loaders

The compact venturi loader is suited to low throughput loading and ideal for masterbatch and additive loading beside the machine.

4 models to load from 1-4 material stations: **Venturi model range**

	Model ML	Model ML-A	Model MPL-AS	Model ML-1 R
Automatic materials loading (Up to 200 lb/hr)	✓	✓	✓	✓
Low-level signal triggers loading until sensor is being covered		✓	✓	✓
Audio and strobe-light alarm options	-		✓ <sup>1</sup>	✓
Timer & material shut-off valve	-	-	✓	✓
Masterbatch & additive loading	✓	✓	✓ <sup>2</sup>	-
Regrind loading	-	-	-	✓

<sup>1</sup>Detects exhausted material supply and stoppages | <sup>2</sup>To stop material flow in case alarm conditions lasts for more than 5 minutes



# Maguire Loading System: GHL Glass-Vu Hybrid Loader

5 lb (3.75 L) / 10 lb (7 L) Clear-Vu, standalone loader that comes with a single-phase motor which is ideal for single station loading of 1 main material.



Please visit [www.maguire.com](http://www.maguire.com) to download our product data sheets.

## 1 Easy Set-Up And Monitoring

Easy viewing of loading status thanks to clear view design

## 2 Efficient Material Flow

Rotating the feed tube ring allows the best air to material mixture for efficient material flow rates, without clogging

## 3 Easy To Operate

User-friendly load set times (2-60 sec) allow operator to fill the glass chamber to desired level

## 4 Simple Access And Cleanout

Easy filter access via hinged, slanted lid for fast cleaning and replacement.  
Easy motor lid removal from loader for quick servicing and replacement



## 5 Quick Material Change Overs

Ease of clean-out allows for quick and easy material changeovers

## 6 Simple Alarms

Audible and visual alarms will notify the user if material does not load correctly

## 7 Loading Options

- Proportional valve
- Purge valve
- Auxiliary alarm device

## 8 Automatic Filter Cleaning

The Maguire GHL loaders come with a patented filter cleaning that completely clears the filter with a blast of air, while ensuring the best air to material mixture is achieved for optimum loading

# Maguire Loading System: GSL Brushless Vacuum Loader

Standalone loader that comes with a robust brushless motor, ideal for high throughputs.



## MODELS

- GSL-12 - 650 lb/hr / 300 kg/hr
- GSL-19 - 1000 lb/hr / 450 kg/hr

# LowPro Conveying System

Self-controlling, extremely compact receiver at up to 80% lower than traditional receivers.

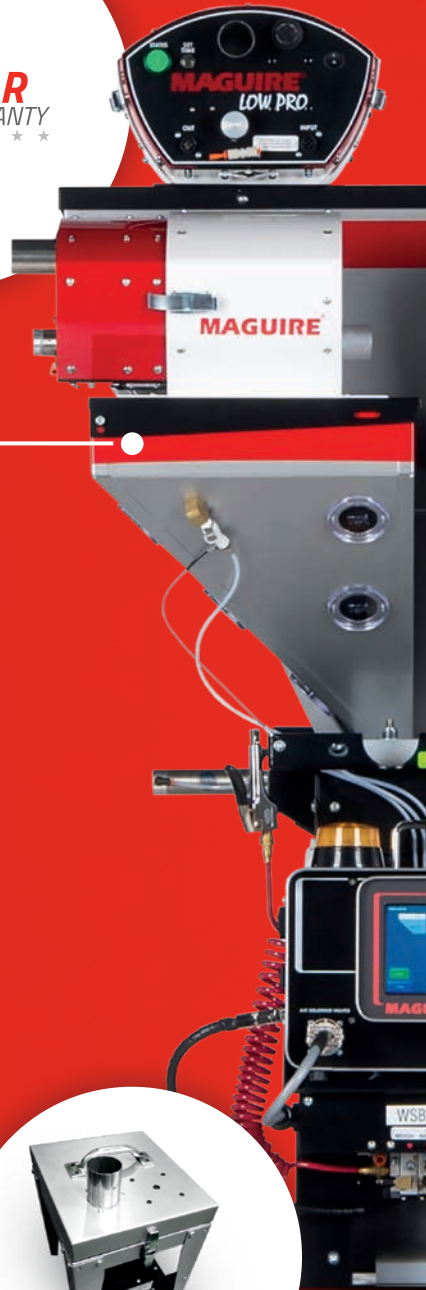

**Low Profile Design**

- Ideal for low headroom applications and standalone solutions for 3 or 4 materials
- Low centre of gravity minimizes effects of vibration from fast-cycling processing machines
- Same capacity, yet 80% lower

**Automatic Filter Cleaning**

- Patented "air blast" design – effective filter cleaning every cycle

**Simplified Maintenance**

- Removable module allows for quick, on-the-fly cleaning and maintenance
- Easy access to filters



SINGLE PHASE BRUSHLESS MOTOR

## LowPro Vacuum Mini Central Power Unit

Model	Power	Voltage	Height		Width		Depth		Standard Inlet Diameter	
			in	mm	in	mm	in	mm	in	mm
MCP	970 W	220VAC/1ph/50Hz	12 1/4	311	10 1/8	257	11 1/8	282	1 1/2	38
		110VAC/1ph/60Hz								

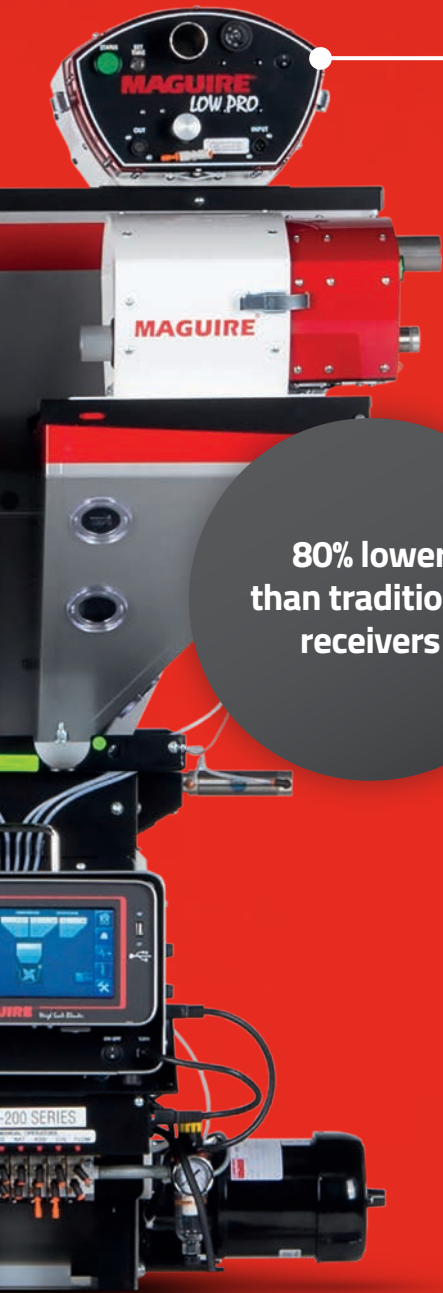

**80% lower  
than traditional  
receivers**



Please visit [www.maguire.com](http://www.maguire.com) to download our product data sheets.



**User-Friendly Side Access**

- All points of access in one easy to access point on side of receiver
- Easy access to: Vacuum pipe, filter, solenoid, alarm and electrical connection

**Autonomous Control**

- User-friendly set time button
- No separate control required to operate multiple receivers, just set load time
- Receivers poll for vacuum taking vacuum and loading when free
- Audible / visible alarm will notify the user if material is not loading on each receiver

**Efficient Material Flow**

- Check valve being pulled up against receiving line when not loading to control and maintain material flow

**Technical Specification**

Model	Capacity		Volume		Height		Standard Inlet Diameter	
	lb	kg	cu.ft	l	in	mm	in	mm
LPR-A4	5.5	2.5	0.14	4	7 5/8	203	1 1/2	38
LPR-A7	10.2	4.6	0.27	7.6	7 5/8	203	1 1/2	38
LPR-A12	18	8.2	0.45	12.7	7 5/8	203	1 1/2	38



# MLS Conveying System

Flexible and compact solutions, ideal for small to medium sized conveying applications.

Compatible with  
FlexBus & FlexBus  
Lite Systems  
Controls

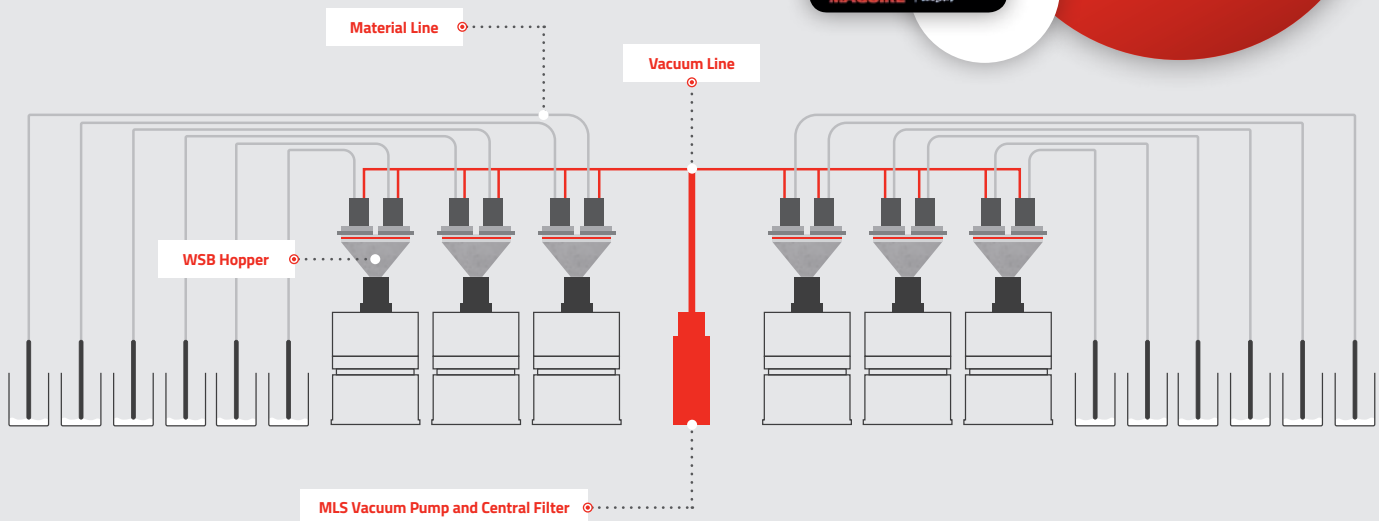

1

## Full View Of The Material Loading

Direct view of material loading makes it easy for the operators to monitor operation and adjust set conveying times

2

## Reduction Of Clogging

Clogging is reduced with a patented deceleration chamber that facilitates separation of material from the air stream and a fast-action slide-gate that prevents pellet entrapment during material discharge

3

## Easy Access For Cleanout

The top cover of the receiver includes the vacuum valve, material inlet and cleanout port

4

## The MLS Maguire Loading System Controller

Two types of control – a basic 8 receiver control or the advanced FlexBus control which is expandable to 5 vacuum groups and 48 receivers per pump

5

## Easy Setting Of Fill Time

Simplifying conveying setup, the push-button activation of the 'autofill' software sets the fill-time for each receiver

6

## Automated Loading

The controller sequences through the various receivers, loading each as either first-in-first-out or priority loading, depending on your requirements

7

## Load Conveying Alarms

A load-failure alarm with reset is incorporated in the controller

8

## Choice Of Compact Vacuum Pump

The power unit is portable and is available with a 1, 2.5, 5 or 10 HP pump / .75, 1.9, 3.7, 7.5 kW pump

9

## Cyclone Dust Collector

Range of cyclones sized to remove dust and fines according to pump size

10

## Modular Layout

The modular layout of the MLS system allows you to expand as your plant grows

11

## 48 Receivers Per Vacuum Group

The basic MLS controller controls up to 8 receivers as standard. The FlexBus control system is capable of controlling up to 5 vacuum groups and per vacuum group up to 48 receivers, allowing the system to grow with you

12

## MLS FlexBus Warranty

All components, except for consumables, are covered by Maguire's 5 year warranty program for the MLS product line

# MLS Vacuum Pump And Central Filter

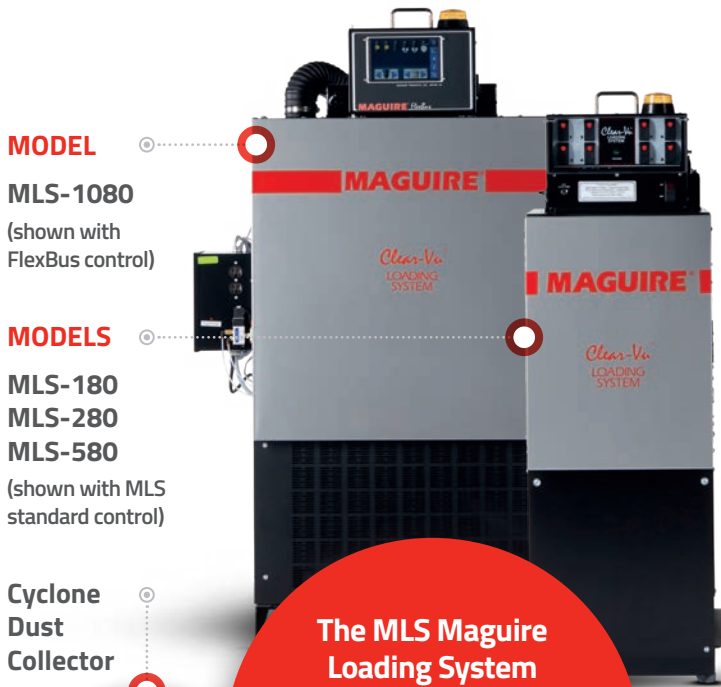

**MODEL**

**MLS-1080**  
(shown with FlexBus control)

**MODELS**

**MLS-180**  
**MLS-280**  
**MLS-580**  
(shown with MLS standard control)

**Cyclone Dust Collector**



**The MLS Maguire Loading System Controller**  
Two types of control – a basic 8 receiver control or the advanced FlexBus control.

Model	Hp	kW	A		B		C	
			in	cm	in	cm	in	cm
MLS-180	1	.75	20	51	48	122	23	58
MLS-280	2.5	1.9	20	51	48	122	23	58
MLS-580	5	3.7	20	51	48	122	23	58
MLS-1080	10	7.5	36	91	58	147	23	58

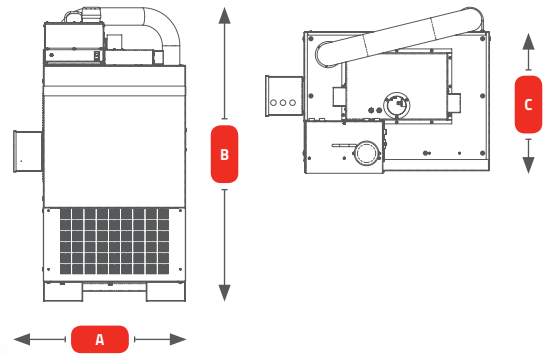

## Range Of Clear-Vu Receivers For Easy Visual Status On Loading

The Maguire Glass-Vu receiver integrates with our Maguire MLS Loading System and our FlexBus conveying system, but can readily integrate with a third party option.

**The Benefits**

- Easy access and cleanout
- Air cannon option for high dust filter cleaning
- FlexBus interface or 24 VDC / 110 V interface for third party systems



**ASRH hopper with AVR-1 to load a feeder**

Model	lb	kg	Height		Width	
			in	cm	in	cm
AVR-15	1	.45	15	38.1	14.5	36.9
AVR-4S-10	4	1.8	22.25	56.5	15.56	39.5
GHR-05	5	2.25	20.5	52.1	11.94	30.3
GHR-10	10	4.5	23.63	60.1	11.94	30.3
GHR-20	20	9	33.56	85.2	11.94	30.3

# FlexBus Lite

Operates up to 1x vacuum pump, 10x receivers with a full feature conveying control, all built within a blender.



## Integrated Conveying Control

- All features and functions of the FlexBus central conveying control but built in within the blender
- FlexBus Lite – Standard on the 4088 touchscreen controller

## Fully Retrofittable

- 4088 touchscreen controller can be easily retrofitted to the majority of Maguire blenders installed already
- Providing the latest generation of controls

## FlexBus Lite Features

- FlexBus features include features typically only found on larger central systems controls including line cleaning, prioritisation, backup pump interfaces, and easy management of materials loading times and receiver and pump setup and control

## Designed For Easy Operation

Our 4088 touchscreen controller uses operator-friendly icons to navigate receiver & pump menus and blender modules.

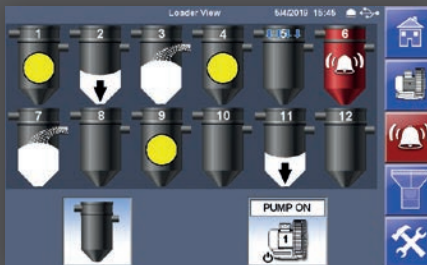

### Home Screen

#### Touch Screen Control Option

Intuitive display shows functions such as:

- ✓ Loader Demand
- ✓ Loader Discharge
- ✓ Loader Filling
- ✓ Filter Cleaning
- ✓ Alarm



### Receiver Features

#### Full System Functionality

Receiver set up allows for full system functionality control of each receiver from the point of view of load times, retries, dump time, filter control, line cleaning, and prioritization.

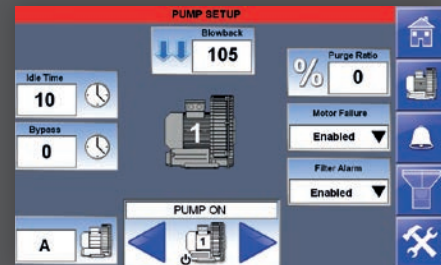

### Pump Features

#### Easy Access To All Features

Pump set up with easy access to all features for complete pump control with options for backup, easy switch over, controls for bypass, filter cleaning, purge, and alarm monitoring.



# FlexBus Central Conveying System

Operates up to 5x vacuum pumps, 48x receivers each, 240x receivers total using one single central FlexBus control.



## Easy Installation

- Single wire connects the control to all receivers and pumps
- Adjusting to complicated material pipework layouts (with different material bulk density and throughput)
- System offers bespoke conveying solutions to meet individual requirements

## Total Conveying Control

- Touchscreen, adjustable load, unload, priority, proportioning, purge, blowback and alarm settings, line cleaning
- Retrofit to existing pumps and existing receivers

## System Compatibility

- Integrates with existing range of Maguire conveying equipment
- Can be integrate with many other manufacturers equipment

## Designed For Easy Integration

Our FlexBus controller uses operator-friendly icons to navigate receiver & pump menus and blender modules.

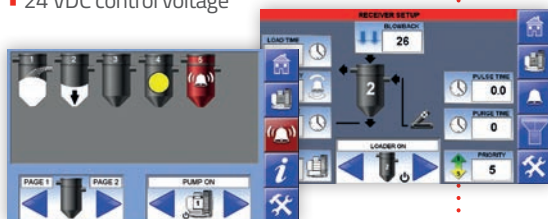
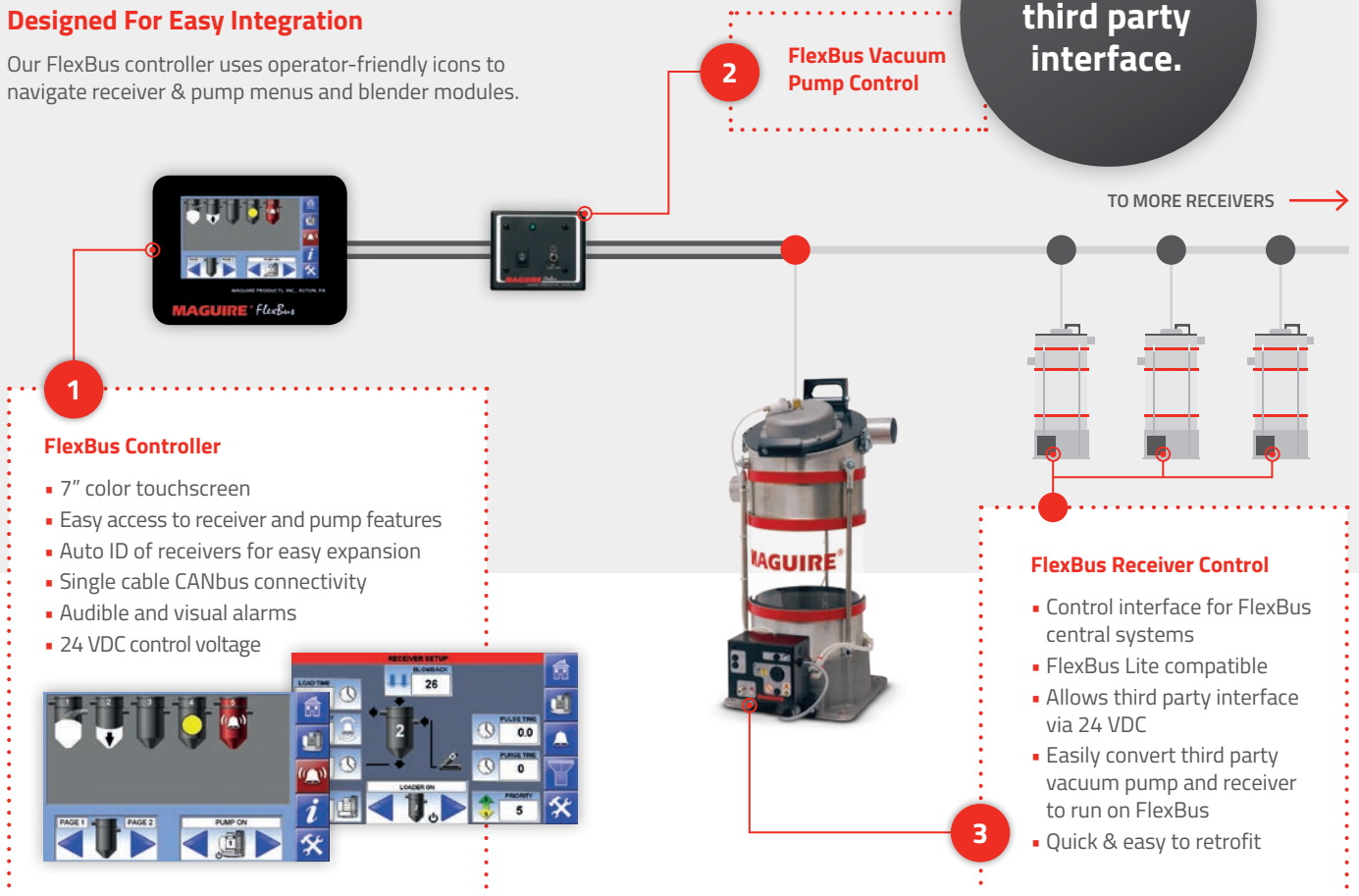

# Where To Find Us

With our extensive network of agents and distributors across the globe, we aim to support our customers locally as much as possible.

- 📍 Maguire Headquarters
- 📍 Agents & Distributors



## Contact Our Teams

**Maguire USA**  
Aston, PA, USA  
T: +1 610 459 4300  
F: +1 610 459 2700  
E: info@maguire.com

**Maguire Canada**  
Ontario, Canada  
T: +1 905 879 1100  
F: +1 905 879 1101  
E: info@maguirecanada.com

**Maguire IMEA**  
Dubai, UAE  
T: +971 4 881 6700  
E: info@maguire-imea.com

**Maguire Europe**  
Staffordshire, UK  
T: +44 1827 338 280  
F: +44 1827 338 285  
E: info@maguire-europe.com

**Maguire China**  
Shanghai  
T: +86 21 5882 3410  
F: +86 21 5882 3420  
E: amber@maguirechina.com

**Maguire Taiwan**  
Taichung City 435  
T: +886 4 2658 1535  
E: mptw.mgmt@maguire.tw

**Maguire Asia**  
Singapore  
T: +65 6848 7117  
F: +65 6542 8577  
E: magasia@maguire-products.com.sg

**Connect With Us:**  
[@MaguireProducts](#)  
[Maguire-Products](#)  
[MaguireProducts](#)

**Innovations For Raw  
Material Handling For  
Over 40 Years -  
Blending, Drying,  
Feeding & Conveying.**



**MAGUIRE**<sup>®</sup>  
*Intelligent Simplicity*