

THE INFORMATION CONTAINED IN THIS DRAWING IS THE SOLE PROPERTY OF MAGUIRE PRODUCTS, INC. ANY REPRODUCTION IN PART OR WHOLE WITHOUT THE WRITTEN PERMISSION OF MAGUIRE PRODUCTS, INC. IS PROHIBITED.

ITEM NO.	QTY.	PART NO.	DESCRIPTION
1	1	55500	Frame-WSB 9
2	1	as5560	Hopper Assy-WSB 9
3	1	as5517	Mix Chamber AssyWSB 9
4	1	as5508 & as5590-M	Mixer Assy-WSB 9
5	2	as3X6	Slide Valve Assy-3 X 6
6	2	as2X3	Slide Valve Assy-2 X 3
7	1	as5581	Front Window Assy-WSB 9
8	1	as5580	Side Window Assy-WSB 9
9	2	5G94S	Enclosure-WSB 9 Side
10	1	as05-9	Weigh Bin Assy-WSB 9
11	1	5G94B	Enclosure-WSB 9 Back
12	1	5G94F	Enclosure-WSB 9 Front
13	1	518-9	Mix Chamber Saddle-WSB 9/18
14	1	asps-01	Level Sensor Assy
15	1	595-9SB	Enclosure-WSB 9 Lower Side
16	2	alc-9	Load Cell Assy-10 kg
17	1	as5506-h	Weigh Bin Holder Assy-WSB 9/18
18	1	m6z403 [mC020P]	Mix Motor-9 1/2 hp [European 50 Hz]
19	2	ncy15	Air Cylinder-3" stroke, 1.06 bore
20	2	ncy2	Air Cylinder-2" stroke, 1.06 bore
21	1	525-9w	Mix Blade weldment
22	1	as5565 /66 /68	Motor Starter Assy-9, 110V / 230V / 400V
23	1	as06-6	Air Assembly-6 Valve
24	1	nv24-6	Air Solenoid Set-6 Valve
25	6	nv24-sol	24V Solenoid Valve segment
26	1	esth392 /393 /403	Manual Motor Starter-110 / 230 / 400V
27	1	eh7456 / 05	Solid State Relay-110 / 230
28	1	es4b862 & 68145	Motor Starter & Overload Relay-400V

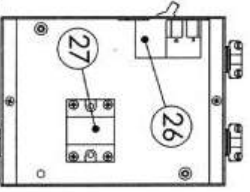

as5565 / 5566  
WSB 9 Motor Starter Assy  
110V / 230V

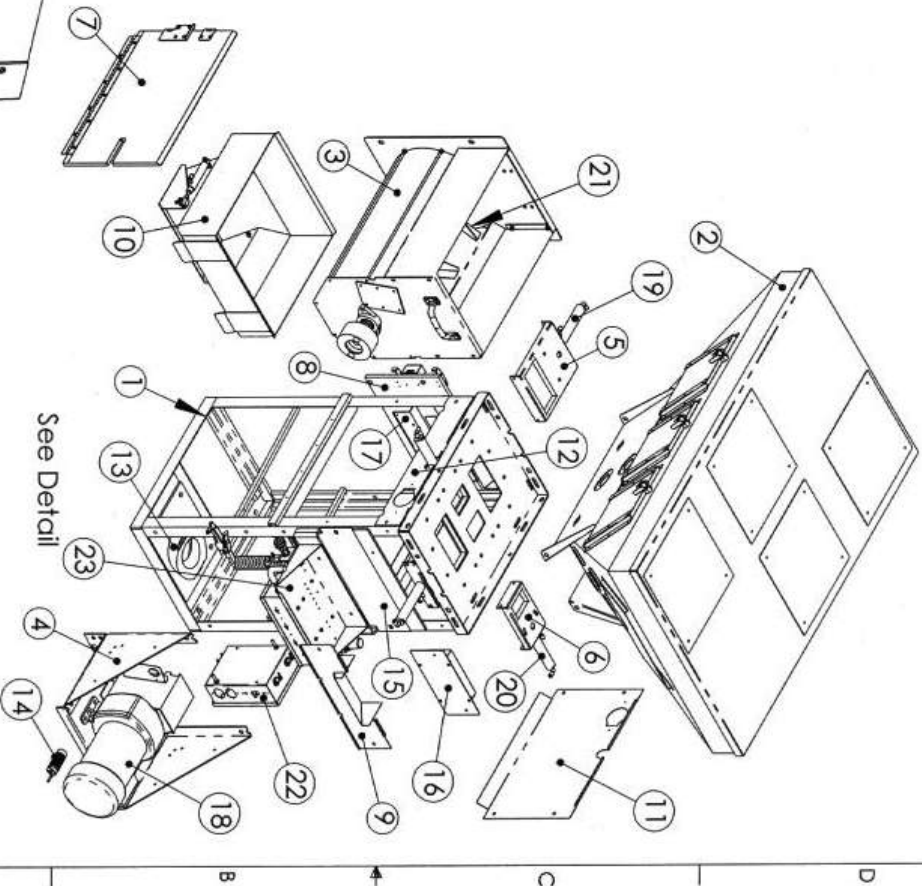
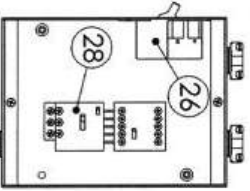

as5568  
WSB 9 Motor Starter Assy  
400V

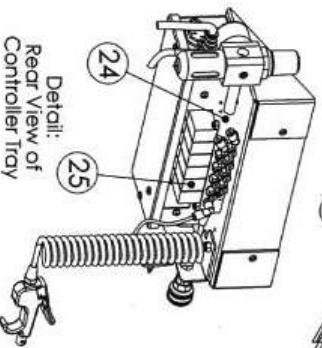

Detail:  
Rear View of  
Controller Tray

**MAGUIRE**  
WSB 940  
Exploded View

UNLESS OTHERWISE SPECIFIED  
DIMENSIONS ARE IN INCHES  
TOLERANCES ARE:  
FRACTIONS    DECIMALS    ANGLES  
+1/32        .XX ± .02        ±1°  
+1/32        .XXX ± .010

FINISH: -  
MATERIAL: -  
DO NOT SCALE DRAWING

SEE DWG. NO. **EXPL-940**  
SHEET 1 OF 1  
NAME: SHEET1  
SCALE: 1:2  
CAB FILE: WSB-940 Exploded