



# Flexible, easily accessible and diverse

Geared towards small to medium extruders, large injection machines and central blending systems.

### 400 series

As part of the WSB 400 series, the 44L can achieve up to 1,400 lb/hr (635kg/hr) and consists of 1 hopper fitted with 4 material compartments.

### Wide range of settings

Each material is dosed by a stainless steel slide gate. The slide gate is capable of dosing a wide range of settings, from as little as 1% to 100%, based on an average density free flowing material (0.65)

### Batch size

The hoppers are mounted above the weigh bin with a default 8.8 lb (4kg) batch size.

### High consistent accuracy

On every material within  $\pm 0.1\%$  on a 1% setting.

### Sequential dispensing

The system tares the weight of the weigh bin and then each material is dispensed – Regrind, Natural, Color and Additive – in sequence to ensure accurate dispenses of every material within the blend.

### Homogenous mix

A complete batch is released into the mixing chamber and mixed with the previous batch to ensure a homogenous mix.

### Control of the mix

Material blending is controlled by a level sensor mounted in the upper part of the mix chamber to retain accurate mixing. When the sensor is covered, the blender will not dispense any further batches.

### Easy set up

Settings are made easily by either user friendly thumbwheels or entering settings directly on the keypad / optional touchscreen.

### Password protection

Special functions can be easily accessed and set via the password protect key.

### Audible and visual alarms

An audible and visual alarm sounds should a batch be incomplete.



### Reporting

Setup and operation reports can be printed direct to a USB key. Alternatively, data is also available via Ethernet or serial ports allowing remote access and monitoring.

### Integration

Integration to other control or ERP systems can be made via leading fieldbus or OPC interfaces.

### Quick cleanout

A compressed air gun is provided for quick cleanout.

### Rapid color change

Easy access to all material contact surfaces of the machine including hoppers, weigh bin and mixing chamber allows for rapid color changes without the use of tools.

### Controller

The Maguire controller monitors and confirms the weight of each ingredient and comes with an optional touchscreen.



## WSB 44L Gravimetric Blender Dimensions

Compartments 1 & 2 - 1.5 cu ft [42 Litres]  
Compartments 3 & 4 - 1 cu ft [28 Litres]

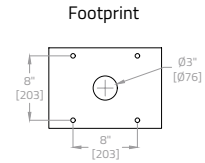
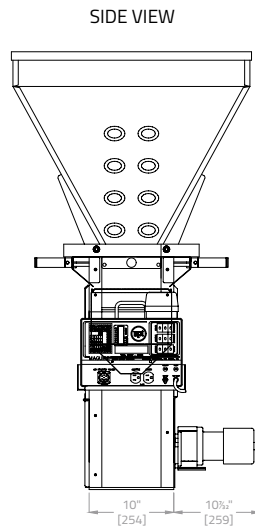
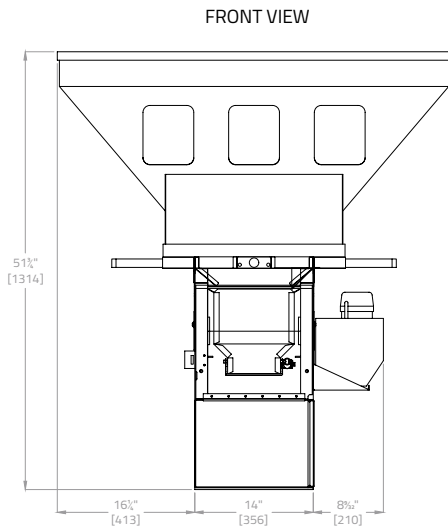

STD WSB Bottom Plate  
1/2" [6.4] Steel Plate

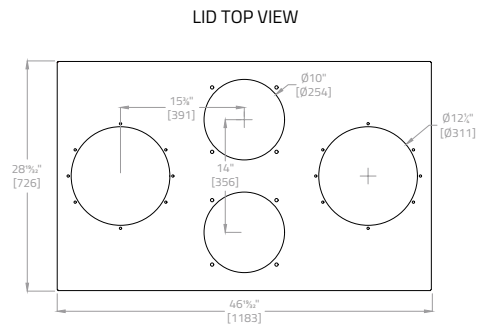

### Technical data

Model WSB 44L	
Maximum Throughput*	480kg/h to 635kg/h 1,050lb/h to 1,400lb/h
Number of Materials	4
Material Dispense Systems	2"-3"x6"or 2"-2" x 6" Slide Gate
Weight	134kg 295lb
Power Supply	120vac - 4.8 Amp 230vac - 2.7 Amp
Operating Air Pressure	4-6 Bar 60-90psi
Air Consumption	0.3 m³/hr 0.17cfm
Shipping Weight	145Kg 320lb
H x W x D	147 x 112 x 82cm 58 x 44 x 32.5in

\*Throughput achieved is influenced by number of materials, how well they flow, vibration and loading consistency - each can effect maximum output of a blender, which in turn effects sizing the correct blender required for an application.

### Key features

- Ideal for large processing machines
- Reduced weight and footprint
- Overall precision of ±0.1% of specified blend
- Compressed air gun for quick cleanout included
- Easy access to all material contact surfaces of the machine including hoppers, weigh bin, and mixing chamber permits rapid colour change without the use of tools
- Proprietary microprocessor-control technology monitors and confirms the weight of each ingredient / touch-screen optional.
- Compensation is made when a variation in dispense weight is detected
- Vibration Weighing management
- Improved documentation capabilities
- 5 Year Warranty



Maguire reserves the right to cancel product or change product, product specifications and data without notice to improve reliability, function, design or otherwise.

### MAGUIRE WORLDWIDE DISTRIBUTION LOCATIONS



#### Maguire USA

Aston, PA, USA  
T: +1 610 459 4300  
F: +1 610 459 2700  
E: info@maguire.com

#### Maguire Canada

Ontario, Canada  
T: +1 905 879 1100  
F: +1 905 879 1101  
E: info@maguirecanada.com

#### Maguire Europe

Staffordshire, UK  
T: +44 1827 338 280  
F: +44 1827 338 285  
E: info@maguire-europe.com

#### Maguire IMEA

Dubai, UAE  
T: +971 4 881 6700  
E: info@maguire-imea.com

#### Maguire Asia

Singapore  
T: +65 6848 7117  
F: +65 6542 8577  
E: magasia@maguire-products.com.sg

#### Maguire China

Shanghai  
T: +86 21 5882 3410  
F: +86 21 5882 3420  
E: amber@maguirechina.com