

WSB 140 HOPPER TOP VIEW  
Controller Side

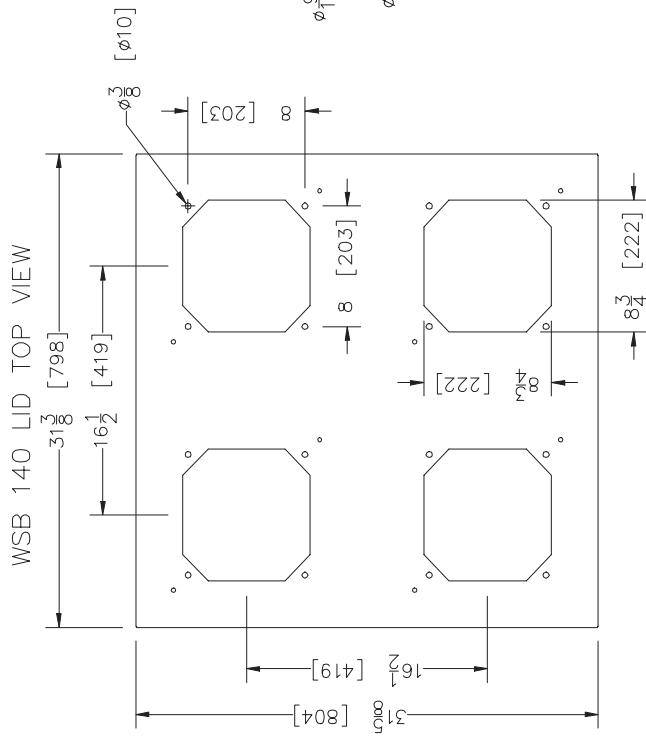
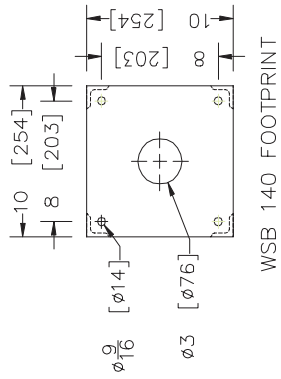
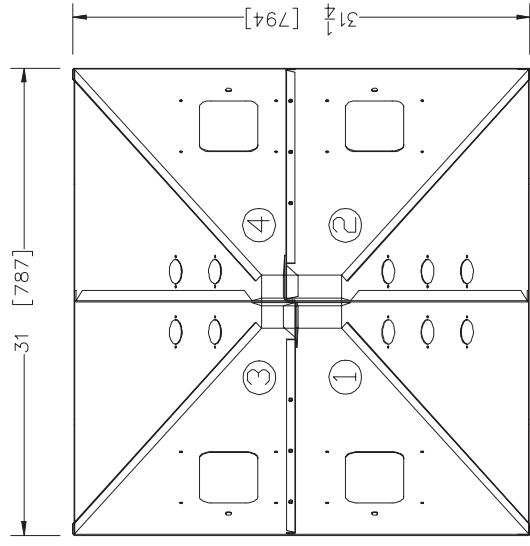

**NOTE:** Practical capacity of each compartment is approximately 1.25 cu. ft. [35 liters].

ALL DIMENSIONS ARE IN INCHES [MILLIMETERS]

WSB 140 FRONT VIEW

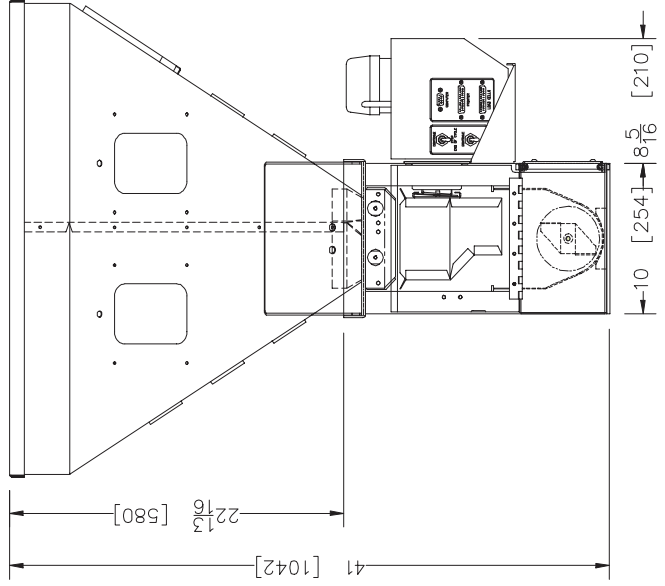

WSB 140 SIDE VIEW

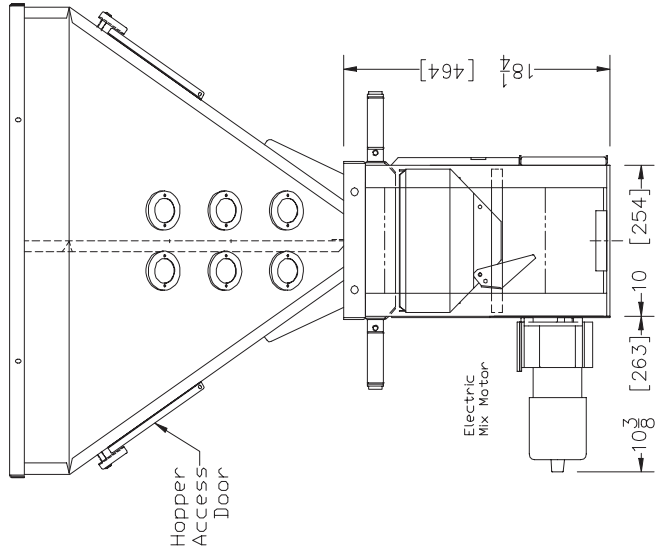

**MAGUIRE PRODUCTS, INC.**  
11 Crozerville Road, Aston, PA 19014  
Tel: (888) 459-2412  
Fax: (610) 459-2700  
<http://www.maguire.com>

WSB 140  
PICTORIAL

DRAWN BY: JSH  
DATE DAWN: 1/6/94  
FILE: WSB/140-pic  
DATE CHANGED: 3/2/99