

WSB 240 FRONT VIEW

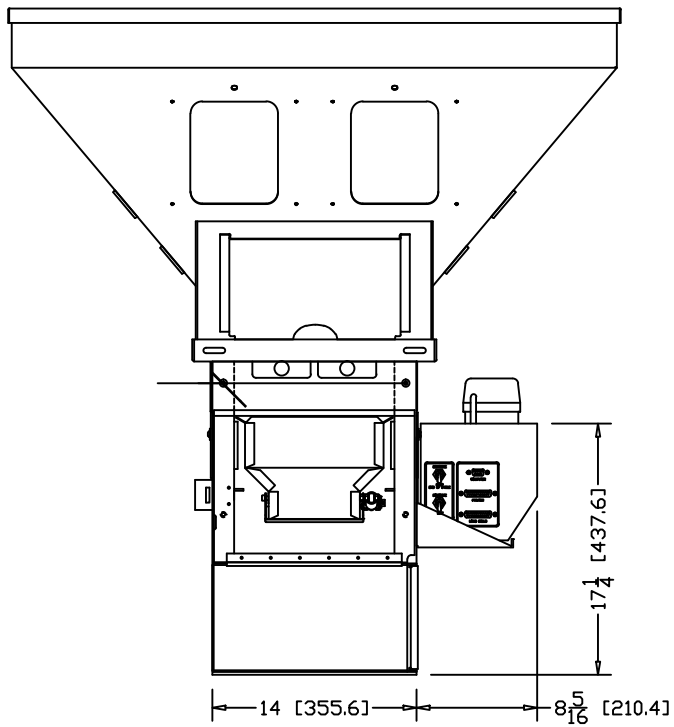

WSB 240 SIDE VIEW

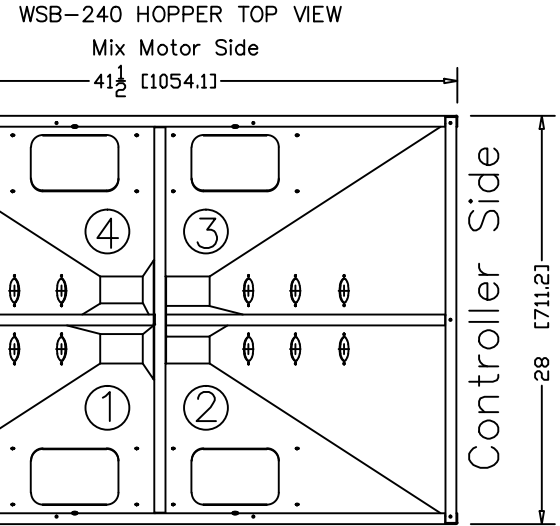
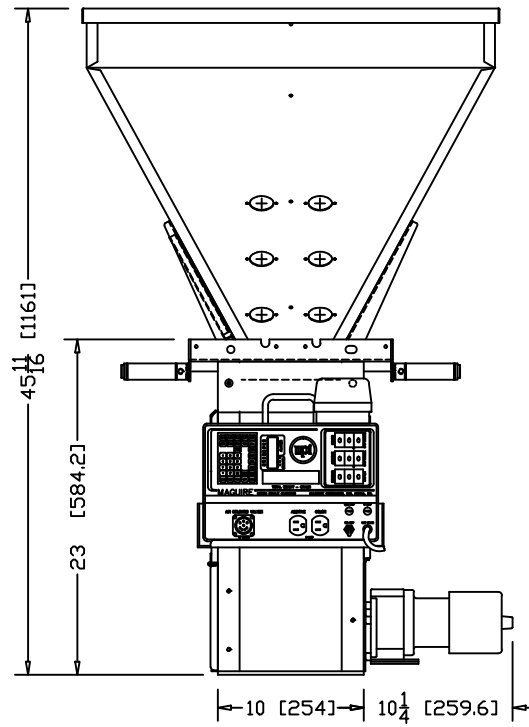

NOTE: Each compartment is approx. 1.2 Cu Ft [34 Litres]

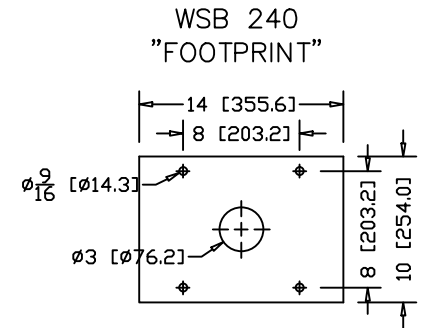

STD WSB BOTTOM PLATE  
1/4" [6.4] STEEL PLATE

ALL DIMENSIONS ARE IN INCHES [MILLIMETERS]

 <b>MAGUIRE</b> PRODUCTS, INC. 11 Crozerville Road, Aston, PA 19014 Tel: (888) 459-2412 Fax: (610) 459-2700 <a href="http://www.maguire.com">http://www.maguire.com</a>	WSB 240 PICTORIAL	
	DRAWN BY: JSH	DATE: 1/7/13
	SHEET 1 OF 1	