

HOPPER CAPACITY IS 4.4
CU. FT. [125 LITRES]

EXTENSION CAPACITY IS 4.5
CU. FT. [128 LITRES]

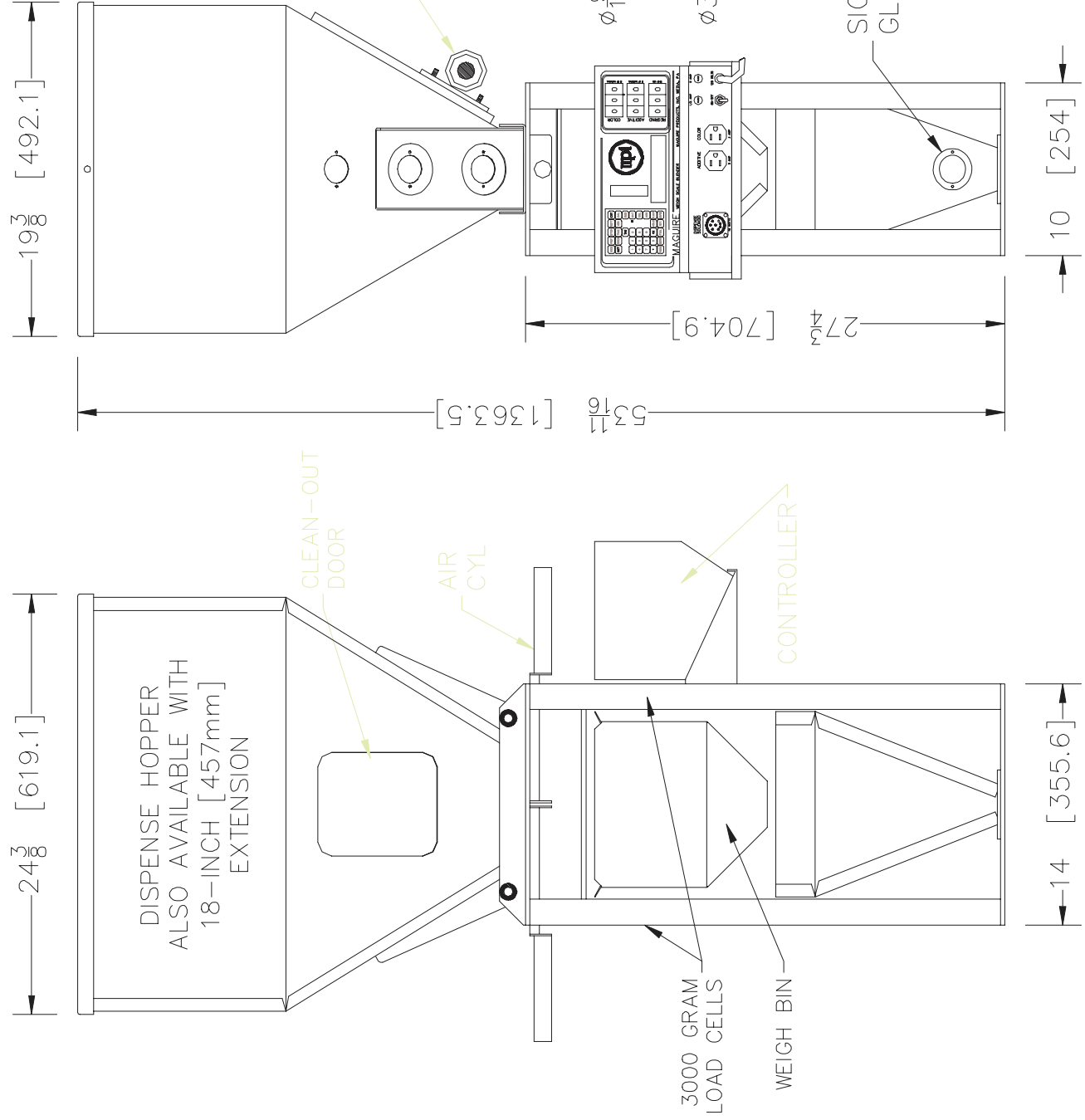

WSD-220
FOOTPRINT

ALL DIMENSIONS ARE
IN INCHES [MM]



MAGUIRE
PRODUCTS, INC.
11 Crozerville Road, Aston, PA 19014
Tel: (888) 459-2412
Fax: (610) 459-2700
http://www.maguire.com

WSD-220 2000 GRAM DISPENSE UNIT	
DRAWN BY: CGC	DATE: 6/6/96
SHEET 1 OF 1	