

MAGUIRE PRODUCTS INC.
FEEDERS

Series MCF[®]

Concentrate Auger Feeder with

Automatic Speed Control and Removable Hopper

INSTRUCTION MANUAL

Maguire Products Inc.
Model MCF
CONCENTRATE AUGER FEEDER
with
AUTOMATIC SPEED CONTROL

Table of Contents

| | |
|---|-----------|
| Assembly and Installation Instructions | 5 |
| Startup Instructions | 7 |
| Normal Operation | 8 |
| Formulas for Setting the Counter | 10 |
| Determining Metering Rate | 11 |
| Principle of Controller Operation | 12 |
| Controller Operation in Conjunction with Re grind Feeder | 13 |
| Principle of Operation – Mechanical | 12 |
| Powder Feeder Option | 15 |
| Description of Controls | 16 |
| Changing Colors | 18 |
| Troubleshooting Controller Problems | 19 |
| In-House Repairs | 21 |
| Troubleshooting Loss of Color | 22 |
| Output Specifications | 23 |
| MCF Features | 24 |
| Warranty | 25 |
| MCF Diagrams | 26 |
| Technical Support and Contact Information | 28 |

Copyright

© 2010 Maguire Products Inc.

The information contained within this manual including any translations thereof, is the property of Maguire Products Inc. and may not be reproduced, or transmitted in any form or by any means without the express written consent of Maguire Products Inc.

To every person concerned with use and maintenance of the Model MCF Concentrate Auger Feeder with Automatic Speed Control it is recommended to read thoroughly these operating instructions. Maguire Products Inc. accepts no responsibility or liability for damage or malfunction of the equipment arising from non-observance of these operating instructions.

To avoid errors and to ensure trouble-free operation, it is essential that these operating instructions are read and understood by all personnel who are to use the equipment.

Should you have problems or difficulties with the equipment, please contact Maguire Products Inc. or your local Maguire distributor.

These operating instructions only apply to the equipment described within this manual.

For the latest revision of this manual, visit www.maguire.com

Manufacturer's Contact Information

Maguire Products Inc.
11 Crozerville Road
Aston, PA. 19014

Phone: 610.459.4300

Fax: 610.459.2700

Website: <http://www.maguire.com>

Email: info@maguire.com

ASSEMBLY AND INSTALLATION INSTRUCTIONS

Your unit consists of 4 separate assemblies:

1. The ADAPTOR frame assembly; 10" square, painted black.
 2. The SLIDE assembly; stainless steel.
 3. The HOPPER assembly; with feed auger.
 4. The CONTROLLER / Drive unit.
-
1. A locking latch is located on each side of the SLIDE assembly. Lift these latches up and rotate them forward until they fall freely. Grasp the heavy steel cross bar in one hand and with your other hand slide the motor mount frame straight back until it stops (5 inches). Lift the HOPPER assembly up and out and put aside.
 2. Bolt the CONTROLLER to the motor mount portion of the SLIDE assembly, utilizing the bolts and nuts that are already positioned in the face of the CONTROLLER. Refer to the diagram on the next page for assistance. The Stainless mounting surface goes against the controller with the square plastic block installed last, over the two longer top bolts.
 3. The ADAPTOR frame mounts under your natural material hopper. In selecting the proper ORIENTATION for mounting, consider the following:
 - * Clearance for the removable hopper.
 - * Clearance for the controller in its pulled-back position.
 - * Easy viewing and access to the controller front panel.
 - * Access to the REAR calibration port near the controller.
 - * Access to the FRONT calibration port near the adaptor frame.
 - * Ease of removal of the hopper.

Before drilling the bolt pattern, remember that the FEEDER will hang from the side with the square hole in the baffle plate.

4. Remove the existing natural material hopper from your process machine. Locate and drill the proper bolt pattern on both top and bottom plates of the 10" square ADAPTOR frame. This frame will be bolted directly to the feed throat of your process machine and the natural material hopper will be bolted on top.

NOTE: The TOP of the ADAPTOR frame has the 3" ROUND hole.
The BOTTOM plate has the SQUARE hole in it.

5. Once the unit is bolted into place and your hopper is replaced on top of the adaptor frame, you may now hang the SLIDE assembly from the proper side (there is only ONE proper side; the side with the HOLE into the flow chamber). The SLIDE assembly must be OPEN to facilitate hanging it on the ADAPTOR assembly. Tilt unit up and slip one end of the cross bar behind a corner post. Slip other end of cross bar behind other post, center the bar, then lower to a resting horizontal position.
6. Install the HOPPER assembly and slide the CONTROLLER forward until the side latches engage and lock. Be sure the drive coupling properly engages the auger.

CONCENTRATE FEEDER ASSEMBLY PICTURE

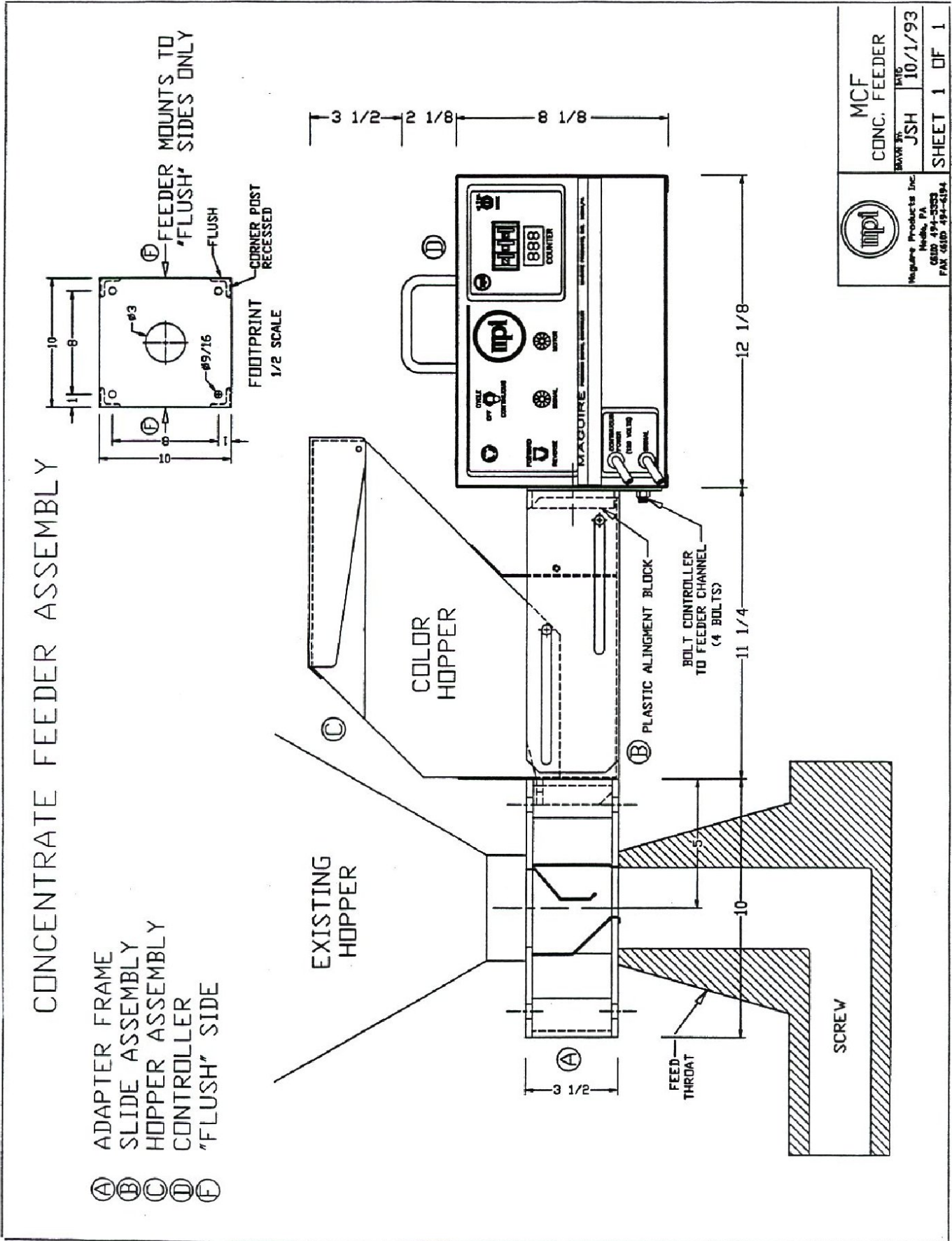

| | | |
|---|--|--|
| | MCF | |
| | CONC. FEEDER | |
| DRAWN BY: JSH CHECKED BY: JSH DATE: 10/1/93 | MAGUIRE PRODUCTS, INC. NEWARK, PA (610) 491-4000 FAX (610) 491-4094 | |
| SHEET 1 OF 1 | | |

START UP PROCEDURE

1. Plug the "CONTINUOUS POWER" (black) cord into a standard 120-volt continuous power source.
2. Plug the "SIGNAL" (gray) cord into outlet that is energized only when the screw is turning. This SIGNAL outlet will provide a voltage signal to an internal electronic relay. Signal voltages from 18 to 250 can be handled. For more information about the signal that you must provide, see "SIGNAL SPECS", below.

The main switch should now be set on "CYCLE".

The "screw return", or "SIGNAL ON" time, must be at least one (1) second. If you are not sure that this is always the case, then it is advisable to select another source of power for the signal. INJECTION time would be an excellent choice for a signal. For very short overall cycle times, the CLAMP CLOSE time is usually the longest signal time available. When screw return times are shorter than 1 second, use the INJECTION circuit or CLAMP CLOSE circuit to provide power to the SIGNAL cord.

3. Using the formula provided in this manual, set the counter to the proper setting for the particular part you are molding. Different colors have different bulk densities and different flow characteristics. For this reason each color should be CALIBRATED for METERING RATE the first time it is used. See the FORMULA page for the proper procedure.
4. Your controller will now cycle on and off each time the process machine screw is cycled. Auger speed will adjust automatically. You may wish to verify output by making use of the sample ports to weigh the output from several cycles.

Once a proper setting is verified, it should be recorded for future reference.

SIGNAL SPECS.

Signal voltage can range from 18 to 250 volts, AC or DC. Actual measured "threshold" voltage is 12 volts AC, or 14 volts DC.

When connected to DC, polarity does not matter. In other words, either lead may be connected to positive. Current load varies from 0.007 amps (7 milliamps) to 0.013 amps (13 milliamps).

The screw signal circuitry is optically isolated from the rest of the controller and thus "floats" with respect to the power source of the controller.

Following are typical examples of current loading on your machine screw signal circuitry:

| | |
|---------------|----------------|
| 20 vac: 8 ma | 120 vac: 12 ma |
| 30 vac: 12 ma | 220 vac: 10 ma |
| 50 vac: 13 ma | 250 vac: 10 ma |

NORMAL OPERATION

The following is what to expect during normal operation.

With MAIN POWER cord plugged in, NO power to the SIGNAL cord, Switch on CYCLE:

The display should read zero (0)
The motor light and signal lights are OFF
The motor is NOT running.

IN CYCLE:

Nothing will run until the SIGNAL cord gets power. When the signal cord is powered, the signal light will be lit.

The first time the signal cord gets power, the unit will start running at about 10 rpms and will count down starting from the number set on the counter.

When the count reaches zero (0), the motor will stop.

On all successive cycles, the motor will run at whatever speed is required to finish counting in the time period that matches the PREVIOUS cycle.

If a cycle is SHORTER than the PREVIOUS cycle, the motor will stop before it has counted down to zero (0). The lowest number reached during the countdown will then be displayed.

If you try to simulate machine cycles by turning the CYCLE switch on and off, the controller will consider every cycle as a FIRST cycle and will always run at 10 rpms.

To simulate machine cycles, plug the signal cord in and out of a wall outlet. Shortening of the 'on time' will result in the motor running faster. Lengthening of the 'on time' will result in a slow down of the motor speed. These changes always occur on the NEXT cycle.

BLINKING of the display means that actual motor speed is not up to "target" speed. This occurs normally when the motor is "ramping up" to speed or when you set too high a number on the counter resulting in a demand for a speed that the motor cannot achieve.

If the motor FORWARD - REVERSE switch is switched to OFF, the motor will stop and the display will hold at whatever number it reached in its countdown.

Switching the motor to OFF and then to FORWARD again during a countdown will cause a momentary increase in motor speed as the unit tries to 'catch up'.

CYCLE TIME:

The motor will start to run about 1/3 (.3) second after a signal is received.

If the Signal is less than about 2/3 (.6) seconds long, then the motor will stop and the processor will NOT consider this as a valid cycle. No recalculation of motor speed will occur.

If the signal is over 2/3 (.6) seconds long, then the motor will run for at least 2 seconds even if the signal goes away. This allows time for speed adjustments to occur.

On longer cycles, over 2 seconds, the counter should count down to zero and the motor should stop within the 1/2 second before the end of the signal.

If you are simulating cycles by plugging and unplugging the signal cord, it will be difficult to produce uniform motor speed and count down rates unless you carefully use a watch to produce uniform cycle times.

If power to the signal cord ends before countdown is complete, the motor stops immediately and the number of counts remaining is held on the display.

IN CONTINUOUS:

The signal cord has no effect (unless the MODE switch is set to the right).

The motor runs at a speed controlled by the counter setting.

If the setting is above the maximum speed possible, then the motor just runs at full speed and the display BLINKS. Full speed will display about '90' for most models.

BLINKING of the display is NOT NORMAL except during speed changes.

If the FORWARD - REVERSE switch is turned OFF, a display of one (1) will result and the motor will not run.

ALL UNITS:

If at any time should the processor become confused and fail to run the motor properly or display the proper numbers, the unit will 'restart' itself after a delay of about 4 seconds.

FORMULAS FOR SETTING THE COUNTER CONCENTRATE FEEDER

INJECTION MOLDING (Cycle Mode):

1. Determine the WEIGHT of the entire shot IN GRAMS. This is the combined weight of the part or parts plus the runner, if any, that is molded each cycle.
2. Determine the POUNDS per 100 of color required. This is the pounds of color that you use for each 100 pounds of natural material used.
3. Determine the METERING RATE for each color in grams/100 counts. Metering rate is the weight in grams of color that is metered when the counter is set to 100. See the next page for instructions on determining Metering Rates.
4. Set the digital counter using the following formula:

$$(\text{shot wt}) \times (\text{lbs}/100) / (\text{grams}/100\text{ct}) = \text{Setting}$$

Example: Entire **shot weight** (parts and runner) = 400 grams
 4 **lbs** of color required per **100 lbs** of product.
 Metering rate = **52 grams/100ct.**
 $400 \times 4 / 52 = 30.76$ -- Set Counter to 31

EXTRUSION (Continuous Mode):

1. Determine the extruder output in pounds per hour.
2. Determine the POUNDS of color required per 100 pounds natural.
3. Determine the METERING RATE in grams/100 counts (see next page).
4. Set the digital counter using the following formula:

$$(\text{lbs}/\text{hr}) \times (\text{lbs}/100) / (\text{grams}/100\text{ct}) \times .71 = \text{Setting}$$

Example: Extruder output = **900** pounds per hour
 lbs of color required per **100** pounds natural = **5.5**
 Metering rate = **42 grams/100ct**
 $900 \times 5.5 / 42 \times .71 = 83.68$ -- Set Counter to **84.**

DETERMINING METERING RATE

Different colors have different bulk densities and different flow characteristics. To compensate for these variations and insure ACCURACY, a METERING RATE must be determined for EACH COLOR.

1. You may use a feeder mounted on a machine or you may remove it from its mounting frame and set it on a bench top. You may use one feeder to determine metering rate and apply this information to all feeders that are the same model, (i.e. same auger size and same gearbox drive motor).
2. Have the black power cord plugged in. The process machine does not have to run. The Gray Cycle cord does not need power.
3. If you have removed the feeder from your machine and set it on top of a work bench, then you will easily be able to take dispense samples from the front of the auger.

If you are taking samples while the feeder is still mounted, then release the side latches and slide the controller out as far as it will go. Now also slide the hopper assembly back until the auger coupling engages the motor drive coupling again. The hopper will now be far enough back that you can collect samples from the front of the auger.

If obstructions on your process machine make calibration from the front impossible, you may also calibrate by metering backwards and collecting a sample from the rear calibration port.

To do this: Uncover the rear port opening by sliding the white plastic collar back. Set the motor switch to REVERSE. Calibration in this manner is not as accurate as metering out the front. Samples are generally about 5 to 10 percent heavier when metered out the back.

4. To collect a calibration sample, turn the CALIBRATION knob (upper right corner) to "CAL" (CALIBRATE) and switch to CYCLE. This will force one cycle of 100 counts to be dispensed.

Another way to accomplish the same thing is to:

- Set the counter to 100.
- Plug the SIGNAL cord into a standard outlet.
- Switch from OFF to CYCLE.
- This will force one cycle of 100 counts to run.

5. Run several initial calibration cycles to allow metering rate to stabilize. Run several cycles and record the GRAM WEIGHT metered each cycle. Take the average of these weights and record it as the METERING RATE for the particular color you are testing. Use this number in the formula where it asks for (grams/100cts).

Example: Each CALIBRATION cycle produces 55 grams output.
Your METERING RATE is 55 grams/100ct.

Typical metering rates are 30 to 60 for model 8-34 (1 inch auger, #34 motor), and 4 to 8 for model 4-34 (1/2 inch augers, #34 motor).

PRINCIPLE OF CONTROLLER OPERATION

The MAGUIRE Digital Controller provides the precise speed regulation and metering control necessary to assure absolute accuracy over color usage. The Controller signal cord is plugged into an outlet that is energized only when the process machine screw runs. During each screw return cycle, the motor runs and color is metered into the throat of the process machine.

Since metering rate is directly related to motor output shaft rotation, accuracy is obtained by controlling the exact degree of rotation of the drive motor. The unique Maguire Products Digital Controller is designed to do this with precision. Our standard model divides each full motor rotation into 159 increments; each increment representing a small fraction of a gram of color being carefully measured out.

The digital counter located on the face of the controller provides the means for predetermining the exact degree of rotation and, therefore, the precise amount of color that will be added during each cycle. When the pre-set count is reached, the motor will automatically shut off, ensuring that no excess color is metered. To determine the proper setting for the counter, a simple formula is used based on percent of color required, a pre-determined metering rate, and total shot weight in grams (or pounds per hour for extrusion applications).

Motor speed is automatically controlled by the internal microprocessor to allow color metering to occur uniformly over the entire screw return cycle. The operator need not concern himself with motor speed adjustment. Changing cycle times or fluctuations in plant voltage are automatically detected and compensated for and, therefore, will have no effect on metering accuracy.

The controller contains a 1/27 HP D.C. Permanent Magnet motor with variable speed control of from approximately 50 to 3000 RPMs. In the standard configuration, the motor is close coupled to a heavy duty gearbox with a reduction ratio of 53:1. Final output speed of the motor is, therefore, approximately 1 to 56 RPMs. As the motor turns, a "hall effect" pickup device on the motor sends 3 pulses per revolution to the microprocessor controlling it. The gearbox ratio of 53:1 means that 159 pulses (3x53) are received for every single revolution of the motor output shaft.

The purpose of the thumbwheel switch is to pre-set the exact number of pulses that the motor is going to run before stopping. The microprocessor in the controller automatically multiplies the counter setting by a factor of 10. A setting of 16 on the counter will allow the controller to receive 160 pulses or run approximately 1 revolution before stopping. Regardless of how fast or how slow the motor runs, color metering will stop after 1 turn.

In addition to this precise control of color quantity being metered, the microprocessor also controls motor speed using the same pulses for digital tachometer feedback. This ensures that motor speed is precisely regulated regardless of changing torque requirements or variations in plant voltage.

CONTROLLER OPERATION IN CONJUNCTION WITH OUR REGRIND FEEDER

All MAGUIRE Color Feeders are designed to work in conjunction with our REGRIND Feeder which may be purchased separately at some later date if the handling of REGRIND at-the-throat becomes a concern.

This Regrind Feeder would be installed on the process machine at the base of the material hopper just above the throat. When used with our CONCENTRATE COLOR Feeder, the REGRIND Feeder adaptor frame would be mounted directly on top of our COLOR Feeder adaptor frame. The regrind would then enter the flow of virgin resin at the same height above the process feed screw as the color feed. When REGRIND metering starts, COLOR metering is reduced accordingly. For this reason, both components must enter the material flow near each other.

REGRIND Controllers are equipped with 2 standard grounded 110V outlets in the rear that provide both a continuous 110V power source and a "signal" power source to operate a color feeder. Your Maguire Products COLOR Controller, when plugged into these outlets, receives messages from the REGRIND Controller telling it when to reduce coloring and by what percentage. In this way the regrind that is added is not "colored twice".

Instructions provided with our REGRIND Controllers explain proper operation of both units when they are working together.

PRINCIPLE OF CONCENTRATE FEEDER OPERATION

The MAGUIRE CONCENTRATE AUGER FEEDER is a rugged industrial auger feeder designed to meter precise quantities of color concentrate very accurately into the main flow of virgin material directly above the throat of your process machine. Two 10" square steel plates, separated by 4 steel corner posts, form a sturdy, low profile, adaptor assembly. This assembly must be drilled with the proper bolt pattern and then mounted to the throat of your process machine where the main material hopper is currently mounted. The material hopper is relocated on top of the adaptor assembly so that virgin plastic will pass down through the opening in the adaptor.

Fitted to the side of the adaptor frame is a wide stainless steel channel, which serves as the main support for both the hopper auger assembly, and the motor drive controller. The concentrate hopper, constructed of stainless steel and weighing only 12 pounds, is designed to rest in the channel with no securing bolts necessary. It is easily removed by sliding backward several inches and lifting straight up. This ease of removal eliminates the need for a clean-out door or chute. Changing colors is done by carrying the hopper back to the concentrate supply container and dumping the unused concentrate back into the container.

The auger and auger tube is also fitted directly under the hopper and is removed with it during color changes. This feature means that all parts that might hold some color contamination are easily carried to a separate area for thorough cleaning. The auger tube is fabricated from 2.5 inch Celcon and contains the 1" diameter steel auger, which conveys the concentrate forward into the flow of virgin material. When the drive motor is run in reverse, concentrate is transported backwards and discharged out a sample port opening for the convenience of checking output from time to time. Output can also be checked directly from the front of the auger tube when the controller and hopper assembly are slid all the way back to the rear stop.

Virgin material flows through the flow chamber contained in the 10" square adaptor frame. This chamber is constructed of two 1/2-inch thick clear acrylic plastic windows and two stainless steel baffles. These baffles control and direct the flow of natural material. The concentrate is dropped into the flow from an air space and is evenly distributed over the steady and predictable flow of natural material. This assures uniform distribution of concentrate into the natural material. The acrylic windows provide a clear view of the combined flow.

The hopper holds up to 25 pounds of concentrate and contains four clear sight glasses, two on each side, providing the operator with a view of the material level. A hopper extension is available that can double this capacity.

POWDER FEEDER OPTION

For those who wish to meter POWDER or other materials prone to BRIDGING, we offer, at additional cost, our powder feed option.

The only difference between our standard Concentrate feeder and our Powder feeder is the hopper and some additional parts added to the slide assembly

Powder requires the addition of an agitator in the hopper to keep it from bridging. The idea is to keep the auger full of powder at all times. If material can be made to fall into the auger, the auger will move it forward without a problem.

To do this we designed a special hopper, smaller than our standard hopper, with straight sides and a rounded bottom. Inside this hopper is a bar that sweeps the bottom of the hopper, just above the auger, once every 2 auger revolutions. This serves to break any bridging that might occur as material is consumed.

To drive this agitator blade we fit a "V" belt to the standard auger drive coupling and add an agitator drive wheel above the motor shaft.

The powder hopper is interchangeable with the standard concentrate hopper, EXCEPT that the agitator drive wheel interferes with the standard hopper. This drive wheel can, however, be removed without tools.

So, with a little bit of work, both style hoppers can be used interchangeable on the same unit.

DESCRIPTION OF CONTROLS

1. CYCLE-OFF-CONTINUOUS SWITCH

CYCLE: The controller will meter a given quantity of color and will shut off for the remainder of the cycle. Quantity metered is controlled by the setting of the thumbwheel switch. In this mode, motor speed is automatically adjusted by the internal microprocessor based on the time length of the previous cycle and the setting of the counter. A speed is selected that will allow the feeder to stop approximately $\frac{1}{2}$ second before the cycle ends.

OFF: Prevents the controller from running and removes power to the computer controls.

CONTINUOUS: The controller will run continuously as long as 110 volt power is present at the controller power cord. Speed is controlled by and directly follows the setting of the thumbwheel switch. Energizing the "cycle" cord has no effect - with one exception; if the MODE switch is in the "CAL" position (turned to the right) the motor will ONLY run when the SIGNAL cord is energized.

2. MOTOR FORWARD/REVERSE SWITCH

This switch should be in the FORWARD position for all normal operation. Holding the switch down in the REVERSE position will cause the controller motor to run backwards. Color in the auger tube will be metered backwards toward the 'sample' port opening. This is done if you wish to verify color quantity being metered per cycle by weighing the actual metered sample. To assure an accurate reading, allow several purge cycles before weighing.

3. THUMBWHEEL SWITCHES

In the CYCLE mode, the thumbwheel switch setting controls the amount of color metered per cycle. In the CONTINUOUS mode, the setting determines the speed of the motor output shaft.

4. MODE SWITCH

The Mode Switch allows several SPECIAL functions. Located in the upper right corner of the control panel, it can be turned with the aid of a small screwdriver.

NORMAL (mid position)

All functions work as described elsewhere. Approximately $\frac{1}{16}$ turn of the motor can be expected for every count on the counter or 63 turns of the motor for the maximum setting of 999. (These numbers may vary with non-standard models).

FRACTIONAL (left position) (x.1)

CYCLE MODE:

If very small metered amounts are required and calculated settings are 10 or less, these settings may not give you the fine resolution of control that you desire. Turning the Range Switch to the FRACTIONAL position will shift the displayed number left one position with a decimal point appearing between before the last digit. Display format will be (##.#) so that fractional numbers can be set on the counter. A maximum of about 6 turns will result from the maximum setting of 99.9.

Thus, to accomplish the same output as before, you would use a setting such as 030 instead of 003, resulting in a display of "03.0" instead of "003".

CONTINUOUS MODE: Mode switch in left position has no effect

CALIBRATION (right position) (CAL)

CYCLE MODE:

This position will force ONE cycle to run for 100 counts at a speed of about 20 RPMs. The SIGNAL cord need not be energized. When calculating METERING RATES for each color you run, this switch will force the controller to run a proper CALIBRATED output. This output in grams is the Metering Rate (Grams/100ct) used in the SETTING formula.

CONTINUOUS MODE:

This position will allow to the motor to run ONLY run when the SIGNAL cord is energized. In the other positions (NORMAL and FRACTIONAL) CONTINUOUS mode will run the motor WITHOUT the SIGNAL cord being energized.

5. DIGITAL DISPLAY WINDOW

In the CYCLE mode, the window will display a numerical countdown beginning with the three digit counter setting and proceeding to zero. In the CONTINUOUS mode, the window will display motor output shaft speed. Flashing of this display at half second intervals indicates that the motor is not running at the speed necessary to deliver all the color in the time allotted (See TROUBLESHOOTING section for more information). The presence of a decimal point in the display means the range switch is turned to the FRACTIONAL position.

6. SIGNAL LIGHT

The Signal Light indicates power is present at the gray signal cord; in other words, the process machine screw is turning.

7. MOTOR LIGHT

The Motor Light indicates the computer processor is outputting a D.C. voltage to the controller motor; in other words, the controller motor is turning.

CHANGING COLORS

1. If vacuum loader is in use, remove vacuum pickup line from the color container and allow to 'dry' cycle one time to clear the line. Turn loader off.
2. A locking latch is located on each side of the Color Feeder. Lift these latches up and rotate them forward until they fall freely forward to a straight down position.
3. Slide the controller-drive unit straight back until it stops (5 inches). There is no need to turn the controller off.
4. Slide the hopper and auger assembly back a few inches. Grasp the hopper handle in one hand and with the other hand under the back side of the hopper, lift straight up and back.
5. Dump the unused portion of color back in the color container it came from.
6. Slowly remove the auger out the rear of the auger tube, allowing color pellets to fall into the recovery container.
7. Once auger is fully removed, tilt the hopper back slightly until all color runs out the rear of the auger tube opening.
8. Inspect that all pellets and traces of color are completely removed from the hopper. If necessary, blow out the hopper and auger tube with an air gun.
9. Re-insert auger. Hopper is now ready for next color.
10. Seat the clean hopper assembly properly in position, then slide the drive unit forward until the side latches fall into their locked position.

NOTE: Difficulty may be encountered if the drive coupling does not engage properly. If necessary, rotate the auger coupling slightly or wait for a machine cycle to cause the motor to run.

11. Fill hopper with new color.

NOTE: You may find it more convenient to fill the hopper with color before re-installing on process machine.

TROUBLESHOOTING CONTROLLER PROBLEMS

IF YOUR MAGUIRE PRODUCTS CONTROLLER DOES NOT WORK PROPERLY:

1. READ about NORMAL OPERATION, page 6, and compare to your problem.
2. READ the following QUESTIONS to assist in solving your problem.
3. If you are UNABLE to remedy the problem:
 - a. ANSWER, in writing (or by email), those QUESTIONS that apply.
 - b. DESCRIBE the PROBLEM in your own words as carefully as you can.
 - c. RETURN this information with the unit for repair.

| ANSWER QUESTIONS as they apply | |
|---|--|
| YOUR COMPANY NAME: | |
| DATE: | |
| NAME of PERSON who saw or knows the problem: | |
| CONTROLLER SERIAL NUMBER: | |
| Time in service: (new, 1 hour, 1 week, years, etc.) | |
| IF PROBLEM IS WITH OUTPUT | |
| SPECIFICATIONS as they apply: | |
| Injection molding, Shot weight: | |
| Extrusion, lbs/hour: | |
| Liquid color lbs/gal: | |
| Desired output (%): | |
| Tube size (or color): | |
| Viscosity of liquid color (thin, thick, etc.): | |
| Supply and delivery tube sizes and lengths, if not standard: | |
| IF PROBLEM IS ELECTRONIC FAILURE | |
| CIRCUMSTANCES of failure: | |
| During storm: | |
| On Monday morning start up: | |
| Same time as another malfunction in plant such as a fuse blowing on a nearby piece of equipment: | |
| Possibility of incorrect voltage (220): | |
| Possibility of low voltage condition (below 100): | |
| On power-up: | |
| OR after running for how many hours: | |
| Is problem intermittent: | |
| How often: | |
| TESTING results: | |
| Do other controllers fail under same circumstances: | |
| Does controller work when tested in another location: | |
| Does problem come and go: | |
| After how much time: | |

| IF PROBLEM IS ERRATIC OR INCORRECT OPERATION | |
|--|--|
| If running in CYCLE: | |
| What is the COUNTER SETTING: | |
| SCREW RETURN (signal) TIME in seconds: | |
| Are screw return times consistent from cycle to cycle: | |
| If not, list some consecutive screw return times: | |
| Is the problem only at certain settings: | |
| Does display start at the full counter setting at the start of each cycle (it should): | |
| Does the display BLINK during count down: | |
| Does it reach zero (0) before end of cycle: | |
| How long before: | |
| Does display ever go completely blank (it shouldn't): | |
| (it should always show a number or a zero except when blinking) | |
| Is the SIGNAL light lit during screw return time: | |
| Is the MOTOR light lit during this period of time: | |
| Is it counting down smoothly at a steady speed: | |
| If running too slow: what is actual motor output RPMs: | |
| What count is displayed when it stops: | |
| If running too fast: | |
| How many seconds does it take to count down to zero: | |
| If running in CONTINUOUS: | |
| What is the COUNTER SETTING: | |
| EXTRUSION RATE: | |
| Does the display show the full counter setting: | |
| Does the display BLINK while running: | |
| Does the display drift: | |
| Over what range: | |
| Is the SIGNAL light lit: | |
| Is the MOTOR light lit: | |
| Is motor speed erratic: | |

DESCRIBE the PROBLEM

Most problems are apparent and easy to fix. However, the more information we have about what caused the problem, the more we can do to improve our product so that these problems do not occur in the future.

In some cases we may NOT be able to duplicate YOUR particular problem in OUR testing facility. Describing the problem as CAREFULLY and as completely as possible will help us locate and correct any design weakness that might be responsible for the problems you are having.

IN HOUSE REPAIRS

1. If a controller fails to respond properly to counter settings, cycle input signal, or on/off signals properly, you may make an inspection of the internal electronics.

Work only in a relatively clean environment. Inspect all cable connections to be sure each is tight and that proper connection is being made by each individual wire and clip within each connector; individual wire clips can sometimes pull loose from the connector. Inspect all solder connections for broken wires or improper solder connections.

Inspect the magnet holding cup on the rear of the motor. If this assembly should loosen, this will adversely affect motor control. Take care not to disturb or damage the electronic hall effect device that is attached to the rear of the motor. Repairs to printed circuit boards should not be attempted. Generally, if a component fails it indicates a condition that may have caused other components to fail as well. Boards should be returned to the factory for repair. A blown fuse on a circuit board usually indicates that other problems are present. A new fuse of similar size and rating may be substituted but if it blows again, the board should be returned to our factory for service. **DO NOT EXCEED 5 AMPS** on the board.

2. FLASHING of the number display indicates that the motor is unable to run at the proper calculated speed. One reason for this may be that the counter setting is too high and the cycle time too short for the motor to complete the metering even at full rated speed. The other cause for the flashing display is that an obstruction is slowing the output shaft and the automatic torque limiting feature is slowing the motor intentionally.
3. NO DISPLAY NUMBER at any time is usually a failed power supply. Be sure there is power to the unit. Check the fuse. There is a fuse on the circuit board; however, this fuse usually will not blow unless some other component on the board has failed. Replace only with a fuse of the same amp rating.
4. DISPLAY of ONE (1) in the CONTINUOUS MODE indicates that the processor is attempting to run the motor but is not picking up any RPM feedback from the armature. Check (a),(b),(c) and (d) below if the motor does not run. Check (e) if it does run.

(a) Components may be blown out on the circuit board. A reading of zero (0) VOLTS at the motor FORWARD - REVERSE switch would indicate this.

(b) The FORWARD - REVERSE switch may be turned off or may be faulty.

(c) Brushes on the motor may not be making proper contact with the armature. Sometimes brushes stick in their holders. A DC voltage at the motor leads without corresponding motor rotation would indicate this may be the problem. Removal of the brushes and light sanding of the brush sides will fix this.

(d) The armature may be burned out. This will occur only with continuous overloading and subsequent overheating. Circuit boards are designed to prevent this through a torque limiting feature. Armatures that burn up leave a distinct odor in the control box.

(e) If the motor is running but the display is still one (1), check the magnet holding disk on the motor armature shaft. It should be secure and there should be about 1/16 inch space between the magnet holder and the electronic "hall effect" device on the back of the motor housing. Also check this electronic device for proper location. It must be positioned under the magnet cup and have no broken wire leads.

TROUBLESHOOTING LOSS OF COLOR

1. Check that color supply is adequate.
2. Check that the auger is rotating the proper number of revolutions per cycle:

| | | | |
|-----------|-------|-----------|----------------------------|
| For Model | 4-18: | 60 counts | equals 1 turn of the auger |
| | 4-34: | 16 counts | equals 1 turn |
| | 8-34: | 16 counts | equals 1 turn |
| | 8-94: | 6 counts | equals 1 turn |

The Mode Switch can alter this relationship so that the counts listed above will produce 1/10 as many auger turns.

An incorrect relationship between counts and revolutions indicates an internal electronic problem.

3. Check that the steel drive coupling is securely locked to the motor shaft. The set screw should be checked for tightness.

CONCENTRATE AUGER FEEDER - MAXIMUM OUTPUT SPECIFICATIONS

(Metering Rate for ABS Color @ 50 lbs./cu.ft.)

| Model # MCF/QCC | Auger size | Max RPMs | Continuous Output-lbs/hr | | Min Dispense (one cycle) |
|--------------------|------------|----------|--------------------------|------|-----------------------------|
| | | | Min. | Max. | |
| 4-18 | 1/2" | 30 | .05 | 4 | .003 CC |
| 4-34 | 1/2" | 55 | .1 | 7 | .006 CC |
| 8-34 Std. | 1" | 55 | .7 | 58 | .050 CC |
| 8-94 | 1" | 130 | 1.6 | 135 | .140 CC |
| 16-50 | 2" | 90 | 8.0 | 600 | .540 CC |

To select proper auger size and motor size:

1. Determine maximum extrusion rate in pounds per hour. For injection molding, extrusion rate is approximately equal to tons of clamping pressure; i.e., a 500-ton press extrudes material at about 500 lbs/hour. Very large presses (over 1000 ton) generally don't exceed 1000 lbs/hour extrusion rate.

A more accurate estimate may be made using shot weight and screw return time for any molded part:

$$(\text{Shot Wt.} - \text{Grams}) / (\text{Screw Return Time in Seconds}) \times 8 = (\text{lbs/hr})$$

2. Determine maximum expected color percent usage and multiply this times extrusion rate for maximum expected lbs/hour of color required.
3. Select the standard unit (Model 8-34) if this unit meets your requirements; otherwise, select the auger with the lowest metering rate that meets your maximum requirements.

Examples:

50 lbs/hr x 2% = 1 lbs/hr max. color -- Select model 8-34
 250 lbs/hr x 3% = 7.5 lbs/hr max. color -- Select model 8-34
 1100 lbs/hr x 4% = 44 lbs/hr max. color -- Select model 8-34
 1300 lbs/hr x 6% = 78 lbs/hr max. color -- Select model 8-94

RECOMMENDATIONS

| MODEL | INJECTION MOLDING | EXTRUSION |
|-----------------|--------------------------|-----------------------|
| 4-18 | Up to 50 tons | Up to 75 lbs./hour |
| 4-34 | Up to 175 Tons | 15 to 175 lbs./hour |
| 8-34 (standard) | 50 to 3000 Tons | 100 to 1200 lbs./hour |
| 8-94 | Not Recommended | 300 to 2000 lbs./hour |
| 16-50 | Not Recommended | 1000 lbs./hour and up |

MCF FEATURES

1. STAINLESS STEEL CONSTRUCTION
2. LOW PROFILE adaptor (only 3-1/2 inches high) keeps your virgin material hopper as low as possible.
3. REMOVABLE HOPPER allows for easy clean out and rapid color changes.
4. CLEAR VIEWING WINDOWS allow visual confirmation of color metering and virgin material flow right at the mixing point.
5. BAFFLE CHAMBER allows color to fall into the flow of virgin pellets from an air space. These baffles also assure a predictable flow pattern and, therefore, uniform mixing of the color into the virgin material.
6. UNIQUE "KEYWAY" SLOT in the auger tube prevents unwanted bridging of material between the auger and auger tube, thus assuring a continuously uniform metering rate.
7. Special HANGER design of the entire feeder assembly allows easy removal for maintenance or for interchangeability from machine to machine.
8. Automatic AUGER TUBE SHUTOFF prevents color pellets from spilling when unit is removed for color changes.
9. FOUR CLEAR SIGHT GLASSES for visual check of material in hopper.
10. ONE PIECE AUGER ground from a SOLID STEEL BAR; no welded flights.
11. FLIP UP latches, self-engaging drive coupling, slide back controller; everything comes apart without tools and without difficulty.



WARRANTY - Exclusive 5-Year

MAGUIRE PRODUCTS offers one of the MOST COMPREHENSIVE WARRANTIES in the plastics equipment industry. We warrant each Concentrate Feeder manufactured by us to be free from defects in material and workmanship under normal use and service; our obligation under this warranty being limited to making good at our factory any Concentrate Feeder which shall within FIVE (5) YEARS after delivery to the original purchaser be returned intact to us, transportation charges PREPAID, and which our examination shall disclose to our satisfaction to have been thus defective; this warranty being expressly in lieu of all other warranties expressed or implied and of all other obligations or liabilities on our part, and MAGUIRE PRODUCTS neither assumes nor authorizes any other persons to assume for it any other liability in connection with the sale of its products.



This warranty shall not apply to any Concentrate Feeder which shall have been repaired or altered outside MAGUIRE PRODUCTS factory, unless such repair or alteration was, in our judgment, not responsible for the failure; nor which has been subject to misuse, negligence or accident, incorrect wiring by others, or installation or use not in accord with instructions furnished by Maguire Products.

Our liability under this warranty will extend only to Concentrate Feeders that are returned to our factory in Aston, Pennsylvania PREPAID.

It should be noted, however, that we strive to satisfy our customers in whatever manner is deemed most expedient to overcome any problems they may have in connection with our equipment.

MCF Diagrams

Model MCF
Concentrate Feeder with
Remote Controller Option

| MODEL MCF | AUGER SIZE | MAX RPM | LBS/HR MIN | LBS/HR MAX | DISPENSE (ONE CYCLE) |
|-----------|------------|---------|------------|------------|----------------------|
| 4-18 | 1/2" | 30 | .3 | 4 | .005 cc |
| 4-34 | 1/2" | 55 | .5 | 7 | .01 cc |
| 8-34 | 1" | 55 | 1.8 | 58 | .05 cc |
| 8-94 | 1" | 130 | 4 | 138 | .15 cc |

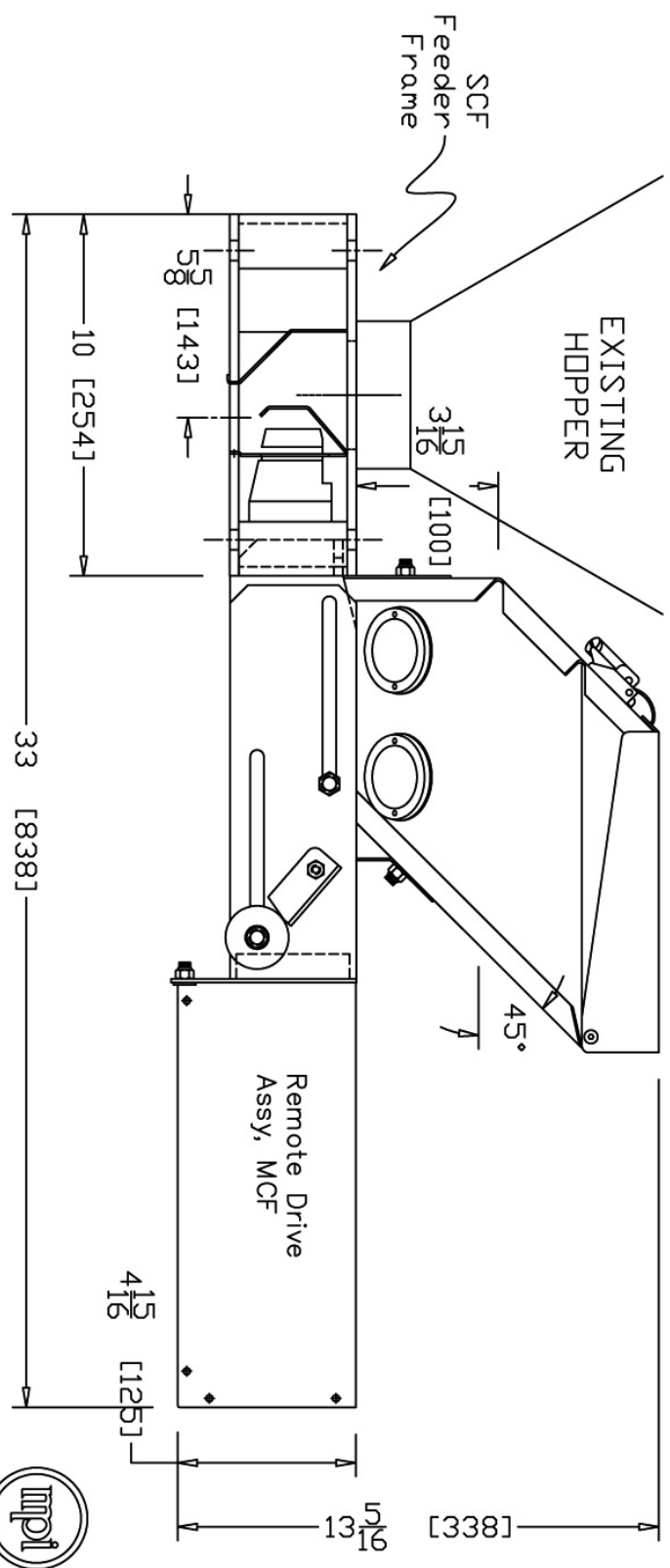
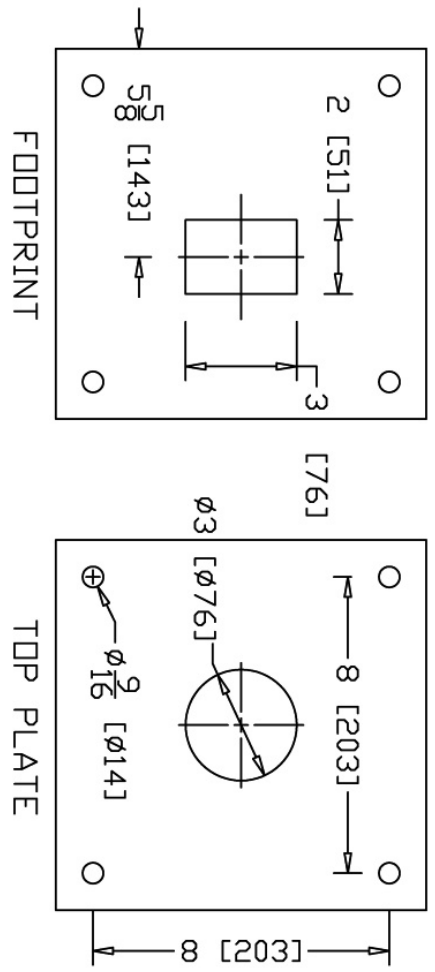

ADDITIVE FEEDER HOPPER IS
APPROX. 0.5 cu.ft. [14 Liters]



MAGUIRE
PRODUCTS, INC.
11 Crozerville Road, Aston, PA 19014
Tel: (888) 459-2412
Fax: (610) 459-2700
http://www.maguire.com

Technical Support and Contact Information

Maguire Products Inc.

11 Crozerville Road

Aston, PA 19014

Tel: 610.459.4300

Fax: 610.459.2700

Email: info@maguire.com

Web: www.maguire.com

Maguire Europe

Tame Park

Tamworth

Staffordshire

B775DY

UK

Tel: + 44 1827 265 850

Fax: + 44 1827 265 855

Email: info@maguire-europe.com

Maguire Products Asia PTE LTD

Main Office

15 Changi North Street 1

#01-15, I-Lofts

Singapore 498765

Tel: 65 6848-7117

Fax: 65 6542-8577

E-mail: magasia@maguire-products.com.sg