

WXB-260 LID TOP VIEW

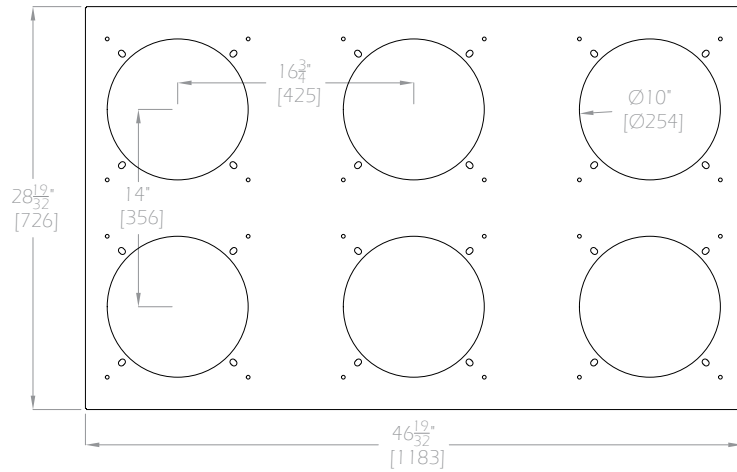

WXB-260 FRONT VIEW

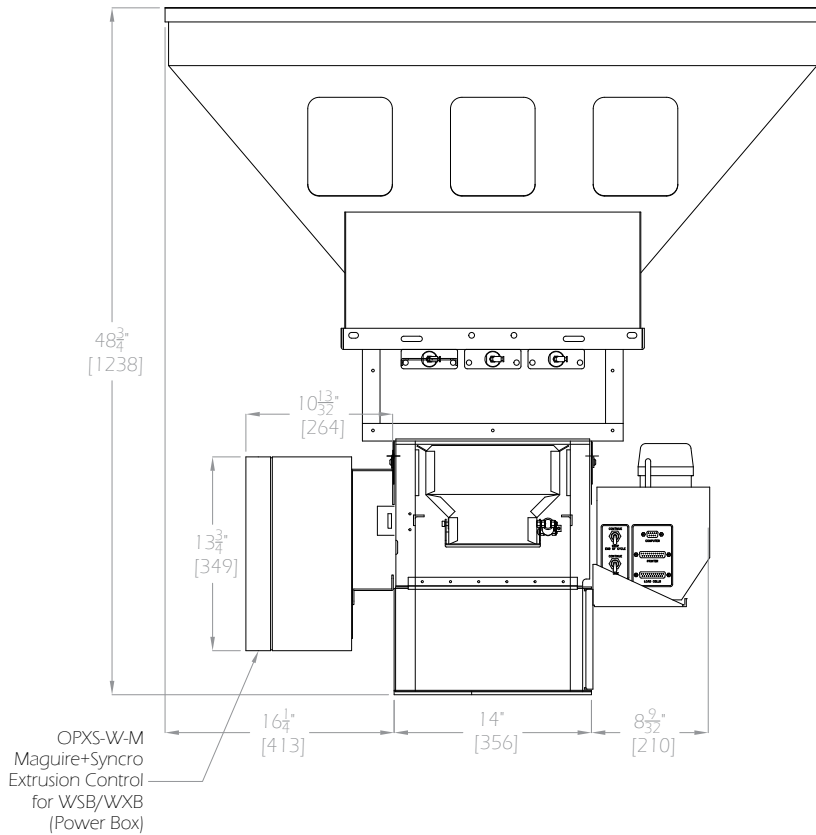

WXB-260 HOPPER TOP VIEW

Mix Motor Side

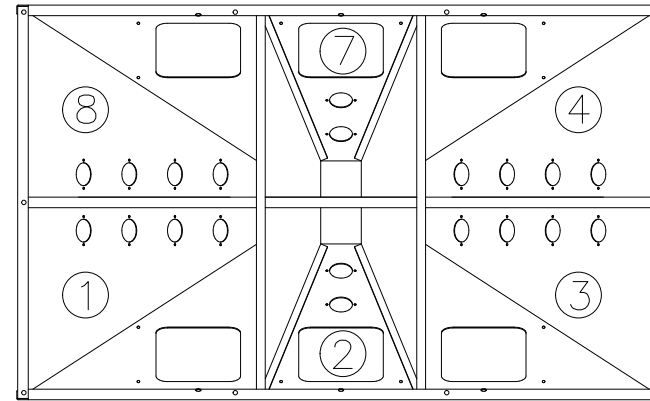

WXB-260 SIDE VIEW

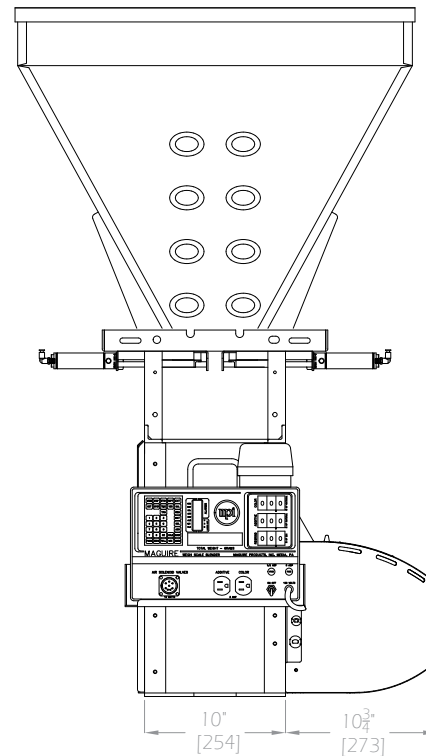

Compartment 1,3,4,8 - 1.5 cu ft [42 Litres]
 Compartments 2 & 7 - 1 cu ft [28 Litres]

WXB-260 Footprint

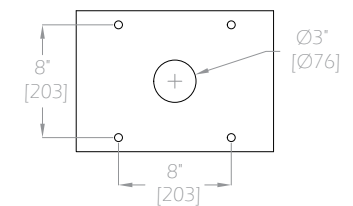

STD WXB Bottom Plate
 1/4" [6.4] Steel Plate

THIS DRAWING IS THE PROPERTY OF MAGUIRE PRODUCTS INC. AND MUST BE RETURNED ON REQUEST. IT MUST NOT BE COPIED OR PASSED TO A THIRD PARTY. DRAWING IS NOT TO SCALE.

TITLE		WXB-260	
DRAWN	FF	DATE	17/02/2019

MAGUIRE[®]
 Intelligent Simplicity