

MAGUIRE PRODUCTS INC.

MLAN[®] COMMUNICATIONS PROTOCOL

MLAN[®] Protocol Manual

Maguire Local Area Network

Communications Protocol for

WSB, WST, LIW, MGF, LPD

Maguire Products Inc.

MLAN Protocol Manual

Table of Contents

Overview	5
RS-232 Communication Wiring	5
Protocol Information	9
WSB, WST, Touchscreen, LIW MLAN Command Index	15
MGF MLAN Command Index	68
LPD MLAN Command Index	100
Appendix B – Get All Parameters	107
Acknowledgement of Typos	112
Technical Support and Contact Information	113

Copyright

© 2024 Maguire Products Inc.

The information contained within this manual including any translations thereof, is the property of Maguire Products Inc. and may not be reproduced, or transmitted in any form or by any means without the express written consent of Maguire Products Inc.

Manufacturer's Contact Information

Maguire Products Inc.
11 Crozerville Road
Aston, PA. 19014

Phone: 610.459.4300
Fax: 610.459.2700

Website: <http://www.maguire.com>

Email: info@maguire.com

I. MLAN Protocol Overview

This manual is intended to provide information for individuals who are writing software for Programmable Logic Controllers (PLCs) and need to communicate with the Maguire Weigh Scale Blender directly. The protocol that is used is called the Maguire Local Area Network (MLAN) protocol. Aside from writing your own programs, Maguire Products offers the G2 Software program as well as OPC profiles, which utilize the protocol described in this manual. The G2 Software program provides material usage tracking reports and remote access of the basic control settings, such as recipes (materials and settings), work order numbers, and operator numbers. For more information on these programs please call Maguire Products, Inc. and ask for information on the G2 Software.

For a complete understanding of the operation of the Weigh Scale Blender (WSB), Maguire Weigh Scale Totalizer (WST), Maguire Loss-In-Weight (LIW), the Maguire Gravimetric Feeder (MGF), or the Low Pressure Dryer (LPD), it is recommended that you have the appropriate controller manual(s) available as a reference.

All numbers in this document are assumed to be decimal (base 10) unless otherwise noted.

The WSBs serial based communicate at a baud rate of 1200, with 8 data bits, no parity, 1 stop bit (1200,8,N,1) and no flow control.

Ethernet - All Maguire controllers sold after mid-2007 are equipped with Ethernet for communications. The WSB 12-12 controllers have both Ethernet and serial on the controller. For Maguire controllers that do not have Ethernet onboard, an Ethernet to Serial converter can be used to convert the serial communications port on the controller to Ethernet. The serial based MLAN Protocol can then be encapsulated over TCP/IP and sent over an Ethernet network.

II. Serial based Communication Wiring (MLAN or RS-232)

Weigh Scale Blender (WSB) controllers can communicate over two different protocols, RS-485 and RS-232. Both are available at the DB9 port on the WSB controller. RS-485, also referred to as MLAN, was used in factory installations prior to Ethernet and continues to be supported in modern Maguire controllers. MLAN over RS-485 required the MLAN Signal Amplifier (part # MLAN-SA). The MLAN-SA is no longer available or supported as of the date on this document. RS-232 is NOT recommended for factory installations but can be used for direct connection to PLC's that require RS-232 and are capable of communicating the MLAN protocol. All communication installation require Ethernet.

MLAN Communication – FOR REFERENCE ONLY – Not recommended for new installations

The cable from the **MLAN-SA** device to all WSB controllers (or to other **MLAN-SA** devices), utilizes the following pin connection:

MLAN TO CONTROLLER CABLE PINOUT		
MLAN-SA DB9 Connector pin # (or terminal strip)	Wire Color	WSB Controller DB9 Connector pin #
1	Black	1
4	Red	4
6	White	6
7	Green	7
5	<i>Shield</i>	connected to housing (not pin 5)

Up to 25 WSB controllers may be connected in parallel using one MLAN-SA. If you are connecting more than 25 controllers or all your cabling (including drops) totals over 2000 feet, additional MLAN-SA devices are recommended.

The **shield** is connected at all points **except** at the controller where is connected to the housing of the cable (see wiring diagram). This shield is intended to tie all external noise to ground at the MLAN-SA/G2-SA, at the computer and at the WSB controllers.

MLAN requires four (4) conductor cable with a shield for conveying information. Wire size should be 18 to 22 gauge. Use 18 gauge for the long runs (especially over 500 feet). Twenty-two (22) gauge is recommended for the “drops” to each controller. Twenty-two (22) gauge wire is used at each controller termination because it solders more easily to the DB9 connector required at each WSB controller location.

We recommend: CAROL WIRE, Part #C2555
or BELDON WIRE, Part #9402

Conductors are Black, Red, White, and Green, plus a shield.

Black	is the positive power supply (16 to 24 volts)
Red	is the neutral from the power supply
White	is communication from PC to WSB controller
Green	is communication from WSB controller to PC

Wiring generally requires a single cable run through the ceiling over all the process machines with “drops” to each controller. This main wire may “T” off to other locations if required for more efficient wiring. Be sure to read the WIRE CONSIDERATIONS section on page 7. See Wiring Diagram, page 8.

RS-232 Communication (for limited applications)

RS-232 uses direct connection from the computer to the WSB controller. This type of communication is reliable for short runs where little or no “noise” or static interference is present. This may be the case in a lab or another closely controlled environment. A low noise environment is not common in a factory and we do not recommend RS-232 for factory installation.

Other restrictions are that the computer must be close (less than 50 feet) to the WSB controller and can only communicate with a few units (maximum of three). If all three conditions are met, then you may cable directly to the RS-232 serial port on your computer without any other hardware interface. Under these circumstances, the MLAN-SA is not required. The proper pin connections are as follows:

RS-232 TO WSB CONTROLLER CABLE PINOUT			
WSB DB9 Connector	Computer Connector		
pin #	DB9	or	DB25
3	3		2
2	2		3
5	5		7 and 1
	6, 7, 8		4, 5, 6
	pins tied together		

Do NOT use a standard off-the-shelf cable. Standard cables have ALL pins connected, or at least more than just those listed above. ALL pins connected will NOT work. You must wire a special cable according to the diagram provided. You may also obtain these cables from us.

Wiring Consideration

The wiring of your communication lines is very important for reliable operation. To minimize problems, consider the following:

1. Communication lines are **low voltage** lines. Be sure that these lines are not bundled to any high voltage lines. If you run them in conduit, do not run high and low voltage lines together.
2. It is not necessary to run this wire in conduit. If you do run cables without conduit, do not wire tie these lines to material conveying lines or other conduit containing high voltage or high amperage electrical lines.
3. Keep all **communication lines** away from all **vacuum loader conveying lines**. Conveying plastic produces **extreme** static charges. An electrical line, even in conduit, that runs next to a vacuum line, can introduce extreme static pulses into the processor. Keep these lines **separated** from conveying lines.

MLAN INTERFACE WIRING EXAMPLE

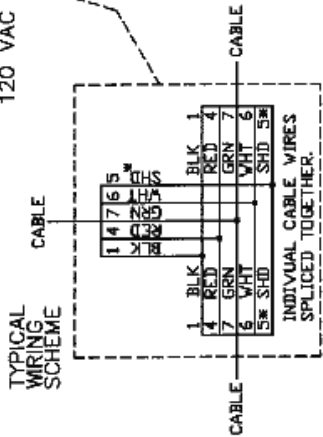
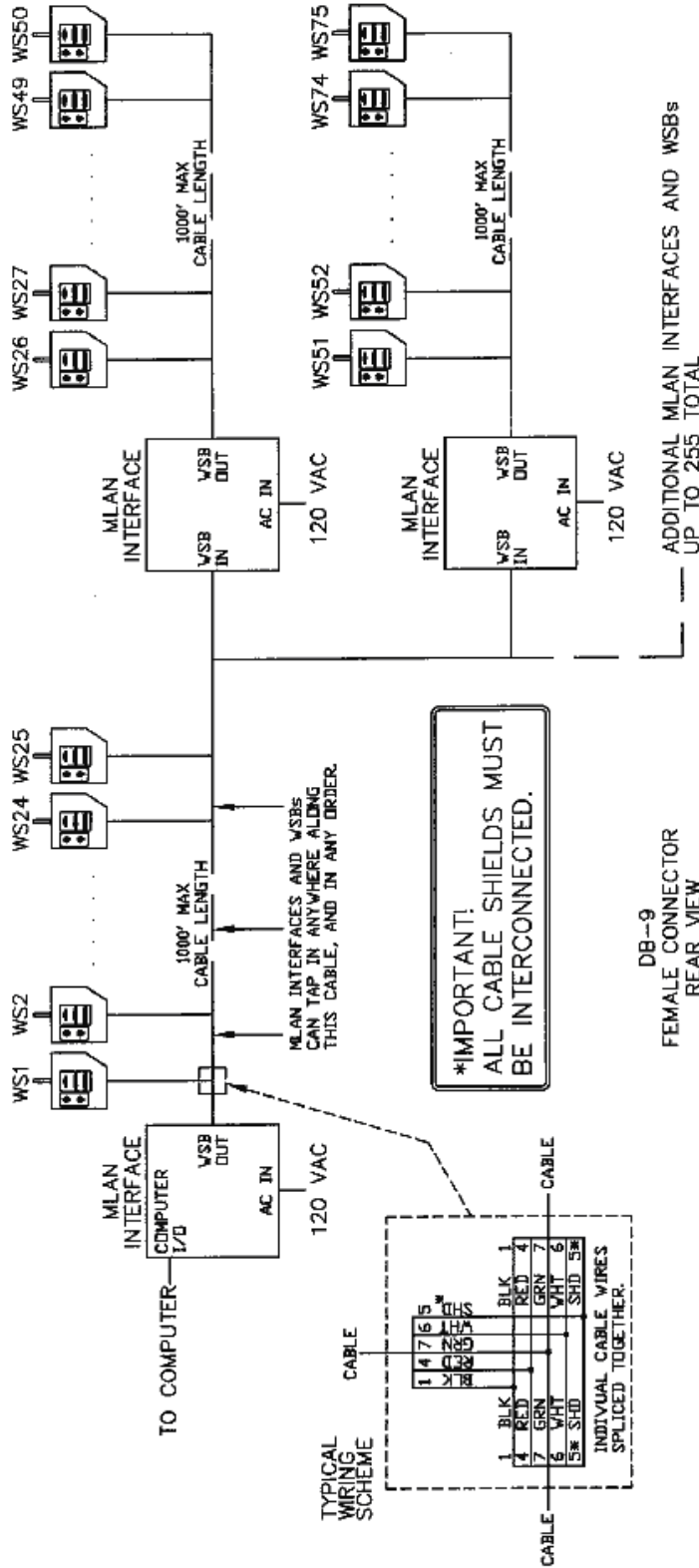

DB-9
FEMALE CONNECTOR
REAR VIEW
(SOLDER SIDE)

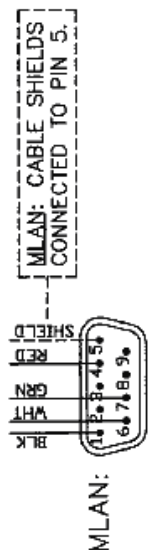

MLAN:



WSB:

NOTE:
ALL BULKHEAD CONNECTORS ARE MALE DB-9 ON BOTH MLAN INTERFACE UNITS & WSBs.
ALL CABLE ENDS ARE FEMALE DB-9 CONNECTORS.

DB-9 PIN#	CAROL WIRE #C 2555	BELDEN WIRE #9402
1	BLACK	BLACK
4	RED	RED
7	GREEN	GREEN
6	NATURAL (WHITE)	WHITE
5*	SHIELD	SHIELD

IBM DB-25	IBM DB-9	MLAN DB-9	FUNCTION
3	2	2	MLAN OUT TO IBM
2	3	3	MLAN IN FROM IBM
1,7	5	5	GROUND



MAGUIRE PRODUCTS INC.
11 Crozerville Road
Aston PA, 19014
Tel: 610-459-4900
Fax: 610-459-2700

MLAN INTERFACE WIRING EXAMPLE	
DRAWN BY:	JSH
DATE DRAWN:	5/17/95
SHEET#	1 OF 1
DATE CHANGED:	9/25/96

III. Protocol Information

All communications between the WSB controller and the computer are initiated by the computer. Each WSB controller monitors its own communication port continuously for an incoming command, and responds only when addressed.

When a command is received, the “address” field of the command is checked first. The controller responds only if this address matches its own assigned address. All WSB controllers, however, respond to commands when the address field is set to zero. Be sure to assign a unique address to each controller. If two controllers were accidentally assigned the same address, both would answer resulting in a communication data collision, which would garble the transmission.

Some commands send data TO the controller and some request data FROM the controller. Acknowledgment of a correct transmission of data is accomplished in several different ways.

1. When the computer requests data, the controller sends back data without first sending an acknowledgment of the command. By sending back data, the controller is understood to have received the command.
2. If the CONTROLLER detects a faulty transmission from the computer, it will send back a NAK.
3. The CONTROLLER will send back an ACK for any command which requests an action but not data. For example, the erase command does not send back any data, so an ACK is sent back to acknowledge reception.

The frame for all messages and responses is the following:

Address	CMD/RSP Code	data	Checksum	
1	1	0 to n	1	byte(s)

The Address field in all commands indicates which WSB should execute the command. This field can range anywhere from 1 to 255. An address of zero causes all WSBs to respond to the command. It is NOT recommended that address 255 be used for a controller ID since the MLAN for Windows software reserves this ID for special use. The address for a WSB is set using the *66 function, see the WSB manual for more information.

For all commands the checksum is obtained by doing a 1 byte add of all the previous bytes in the command and complementing the result. In other words, to obtain the checksum, add up all of the bytes and then divide by 256, take the remainder, and complement the result. Sample code for calculating the checksum is given below.

All values, transmitted and received, are binary values. All multiple byte values are sent **Most Significant Byte first** (Motorola standard format). For example, the hexadecimal (base 16) number **F0 00 00 00**, would transmit the **F0** byte first. The decimal equivalent (i.e. base 10) of this number is 4,026,531,840. Its binary representation (base 2) is:

```
11110000 00000000 00000000 00000000.
```

WSB controllers may use FOUR component software or TWELVE component software. Commands and responses vary accordingly.

Check Sum Calculations

Sample BASIC function for generating a checksum:

```

FUNCTION CheckSum%(data$)
  cs% = 0
  FOR i% = 1 TO LEN(data$)
    cs% = cs% + ASC(MID$(data$, i%, 1))
  NEXT i%
  CheckSum% = 255 - (cs% AND 255)
END FUNCTION

```

Here is the same function in C:

```

int checksum(char *data) {
  int cs=0;
  while(*data!=NULL) {
    cs += *data;
    data++;
  }
  return 255-(cs%256);
}

```

The BASIC code generates the CHECKSUM in the following manner:

The (FOR/NEXT) portion of the code adds the ASCII value of each character of the “data\$” field, one character at a time into a total field called “cs%”. Full addition occurs with “carries”. Nothing is lost.

The code (cs% AND 255) serves to “mask” the “cs” field so that all bits are cleared to zero except for the last 8 bits. This last byte will have a binary value between 0 and 255.

The same result is achieved by dividing the sum by 256 and saving only the remainder (see the C-code example above); or by adding all data into a 1 character (8 bit) field with no carries saved. But that is not how it is done here. In this case, the “AND” command is used with the value 255 to “mask” or set to zero all bits except for the last 8. What remains is a binary value that ranges from 0 to 255. This is then subtracted from 255 and what is left is used as the CHECKSUM value.

The idea is that the recipient of this data can go through the same procedure (but without the subtraction at the end) and should always end up with a value of 255 as the final answer to this test.

This is the function that TESTS for a correct check sum:

```

FUNCTION TestSum%(data$)
  cs% = 0
  FOR i% = 1 TO LEN(data$)
    cs% = cs% + ASC(MID$(data$, i%, 1))
  NEXT i%
  TestSum% = cs% AND 255
END FUNCTION

```

Again, all characters are individually added into the field “cs%”. This field is “masked” with the “AND” command to leave only the value of the last 8 bits. This value should be 255 (all bits on).

This is the line that actually CONFIRMS that the test was correct:

```

IF TestSum% (portin$) = 255 THEN ...

```

If the answer is 255 then it is O.K. to proceed.

Programming Considerations

Each controller must have a unique address. This unique address/ID will be used to communicate with each controller.

Control software type (4 or 12 component) must be determined. There are three ways to determine the controller's software type:

1. Use the command "Get Settings from Weigh Scale" command code 20
2. Use the command "Get Weigh Scale Type" command code 49
3. Turn the controller off and on again. You will either see "TWELVE" or "FOUR," if you have a relatively new controller. If not, look at the number that appears on the display during power up. This number will have a "T" on the end of it if it is twelve-component software. If there is some other letter present, the controller has four-component software.

Messages and responses are different according to which type of software is used. For example, the "Send Settings to the Weigh Scale" command (command code 19) has different formats for each software type.

Finally, the blender series must be known. Blender load cells read in either tenths of grams or whole grams. The load cells for the 100 and 200 series of blenders read in tenths of grams. The load cells for the 400, 900, and 1800 series of blenders read in whole grams. For example, a response of 234 from a 100 or 200 series blender indicates that 23.4 grams of material have been processed. A response of 234 from a 400, 900, or 1800 series blender indicates that 234 grams of material have been processed.

Summary of all MLAN commands (along with their codes)

Abort Cycle or Retry(27)	Aborts the current cycle or aborts the current cycle retry.
Clear Totals (24)	Resets the totals to zero at the next end of cycle.
Clear Totals Immediately (28)	Resets the totals to zero immediately.
Get Address (54)	Returns the controller's address.
Get All Parameters (22)	Returns all of the parameters and their values.
Get Batch Info (84)	Returns the batch weight, current portion, accumulated total, and batch count. (See WSB manual for more information regarding batches.)
Get Cycle Weight & Time (50)	Returns the size of the last batch/cycle and the duration of time between the last two cycles.
Get CWT - 4-byte update (79)	This is an updated version of command 50 with a 4 byte Cycle Weight.
Get Display (56)	Returns the current LED display buffer.
Get Linespeed Target & Error Accumulators (61)	Retrieves the Linespeed target and error accumulators from the controller.
Get Extrusion Control Mode (60)	Gets the Extrusion Control Mode
Get Parameter (69)	Returns the value of a parameter.
Get Rate and CPL (57)	Gets the downstream equipment rate and the counts per length setting.
Get Settings (20)	Returns the mix percentages and component types along with work order and operator numbers.
Get Star (*) Function Value (71)	Gets the value of the star (*) function. Currently, only *52 and *82 are enabled.
Get Status (53)	Returns the current state of all signal inputs and outputs.

Get Steady State Rate (64)	Returns the steady state throughput rate of the blender.
Get Target Thrupt & Status (29)	Returns the current target throughput and the extrusion control status.
Get Totals (16)	Returns the current totals and resets internal flag.
Get Totals (17)	Returns the current totals without resetting internal flag.
Get Type (49)	Returns the software type (4 or 12) and load cell type (tenths of grams or grams).
Get Version (80)	Returns the version of the software in the controller.
Get Weight Units (85)	Returns the units that the blender is using to display totals, such as pounds or kilograms.
Get Yield (31)	Returns the target Yield for extrusion control.
Send Keystroke (87)	Sends a keystroke. (See "Set Remote Keypad" command)
Send Settings (19)	Sets the mix percentages and component types. Also sets work order and operator numbers.
Set Batch Weight (83)	Sets the batch flag parameter and the batch weight.
Set Date and Time (81)	Sets the date and time for a particular blender. If the address is 0, all WSBs are set with the new date and time and NO response is sent back.
Set Mixer Motor State (66)	Sets the state of the Mixer Motor
Set Parameter (68)	Sets the value of a parameter.
Set Pause Cycle Flag (25)	Pauses the current Cycle Immediately.
Set Rate (58)	Sets a target downstream rate.
Set Remote Keypad (88)	Enables or disable the controller's keypad and/or the "Send Keystroke" command.
Set Steady State Rate (65)	Sets the steady state throughput rate of the blender. This tells the WSB the rate to report back for the "Get Steady State Rate" command. It's useful when you know the rate and you don't want to wait for the WSB to figure it out. Note: if you send it an incorrect rate, the WSB will eventually figure out the correct rate.
Set Star (*) Function (70)	Sets the value of the star function. Currently, only *52 and *82 are enabled.
Set Tag (90)	Sets either recipe number, operator number, or work order number.
Set Target Throughput (30)	Sets the target throughput for extrusion control mode.
Set Voltage (59)	Sets a voltage for downstream equipment.
Set Weight Units (86)	Sets the units that the blender uses to display totals, such as pounds or kilograms.
Set Yield (33)	Sets the Target Yield for extrusion control.
Silence Alarm (82)	Silences the alarm for a particular WSB.
Start/Stop/Status (55)	Either causes the WSB to stop at the end of the current cycle, start up again, or return its current status.
Stop Cycle / Stop Retry (27)	Either causes the WSB to abort the current cycle or the current dispense. Aborting the current cycle causes the WSB to start the next cycle. Aborting the current dispense causes the WSB to start dispensing the next component.

MLAN Command Table

The following table documents when the earliest MLAN commands were introduced into the MLAN communications protocol. In early Maguire Weigh Scale Blender controllers (distinguished by a red display) the chip version number can be found on the MLAN chip within the controller and on the display during boot up of the controller (V=xxxxxx).

NOTE FOR OLDER CONTROLLERS: Depending on the date of firmware in older 6811 controllers (red display), all commands may not be available.

In most cases with the introduction of new commands to the software in MLAN chips, 12 software chips were either first to be updated or both the 12 software and the 4 software chips were updated at the same time. Not all chips are listed below. What is listed are chips that marked a change in the software and were available for testing. If your chip is not listed, it may indicate that your chip did not mark a change in the software or possibly it was not available for testing when this information was compiled. Chips versions numbers indicate a date. For instance, chip "60603A" means 1996 (6), June (06), 3rd (03) followed by "T" for twelve software or "A" for four software. Your chip version number may fall somewhere in between the chips listed below if it is not directly listed.

- Controllers using chips prior to **60603A (06/03/1996)** have an earlier circuit board, which would need replacement if the chip were to be updated.
- Chips after 90317A (03/17/1999) will have all parameters available.
- GET ALL PARAMETERS command may not appear in chips released during first and second quarter of 2001
- Chips prior to 90317A (03/17/1999), please see chart on the following page.

MLAN Command	6811 Chip Version (printed on Chip)
GET VERSION	60603A (06/03/1996)
CLEAR TOTALS	20414A (04/14/1992) or before
CLEAR TOTALS IMM	80609A (06/09/1998)
GET ADDRESS	50925 (09/25/1995)
GET ALL PARAMETERS	60809A (08/09/1996) *
GET BATCH INFO	60603A (06/03/1996)
GET CWT	30913A (09/13/1993)
GET DISPLAY	50925 (09/25/1995)
GET PARAMETER	70205T (02/05/1997)
GET SETTINGS	20414A (04/14/1992) or before
GET STATUS	41019A (10/19/1994)
GET STEADY STATE RATE	60603A (06/03/1996)
GET TARGET THRUPUT STATUS	90317A (03/17/1999)
GET TOTALS	20414A (04/14/1992) or before
GET TYPE	20414A (04/14/1992) or before
GET WEIGHT UNITS	60710T (07/10/1996)
SET REMOTE KEYPAD	60911T (09/11/1996)
SEND KEYSTROKE	60911T (09/11/1996)
SEND SETTINGS	20414A (04/14/1992) or before
SET BATCH WEIGHT	60603A (06/03/1996)
SET DATE TIME	60603A (06/03/1996)
SET PARAMETER	70529A (05/29/1997)
SET STEADY STATE RATE	70916T (09/16/1997)
SET TAG	60710T (07/10/1996)
SET TARGET THROUGHPUT	90317A (03/17/1999)
SET WEIGHT UNITS	60710T (07/10/1996)
SILENCE ALARM	60603A (06/03/1996)
START/STOP/STATUS	60603A (06/03/1996)
STOP CYCLE STOP RETRY	71222T (12/22/1997)
4COMP or 12 COMP XT PARAMETERS	60603A (06/03/1996)

* GET ALL PARAMETERS command may not appear in chips released during first and second quarter of 2001

Weigh Scale Blender (WSB, WST, Touchscreen) and LIW (Loss-In-Weight) MLAN Commands

The Maguire Weigh Scale Blender was the first Maguire product to use the MLAN Protocol commands for data communications. The following commands are available in the latest controller firmware versions. This category includes:

6811 Controllers – First generation controllers with the red-display, 4 and 12 Software chips

12-12 Controllers – Second generation controllers with the blue-display, 4 and 12 Software

Touchscreen Controllers – Includes both Compact Touchscreen and Touchscreen retrofit.

WST (Weigh Scale Totalizer) – a single component Weigh Scale Blender

LIW Controllers – Loss-in-Weigh system controllers

MLAN Command Index:

Command	Page	WSB	Touch	WST	LIW	Command	Page	WSB	Touch	WST	LIW
Abort Cycle or Retry	16	✓	✓	✓		Send Keystroke	44	✓	✓	✓	✓
Clear Totals	17	✓	✓	✓	✓	Send Settings	45	✓	✓	✓	✓
Clear Totals Immediately	18	✓	✓	✓	✓	Set Batch Weight	47	✓	✓	✓	✓
Get Address	19	✓	✓	✓	✓	Set Date and Time	48	✓	✓	✓	✓
Get All Parameters	20	✓	✓	✓	✓	Set Mixer Motor State	49	✓	✓	✓	✓
Get Batch Info	21	✓	✓	✓	✓	Set Parameter	50	✓	✓	✓	✓
Get Cycle Weigh and Time	22	✓	✓	✓	✓	Set Pause Cycle Flag	51	✓	✓	✓	✓
Get Cycle Weigh and Time (4 bytes version)	23	✓	✓	✓	✓	Set Rate	52	✓	✓	✓	✓
Get Display	25	✓	✓	✓	✓	Set Remote Keypad	53	✓	✓	✓	✓
Get Display (Extended)	26	✓	✓	✓	✓	Set Steady State Rate	54	✓	✓	✓	✓
Get Linespeed Target and Error Accumulators	27	✓	✓	✓	✓	Set Star (*) Function	55	✓	✓	✓	✓
Get Extrusion Control Mode	28	✓	✓	✓	✓	Set Tag	56	✓	✓	✓	✓
Get Parameter	29	✓	✓	✓	✓	Set Target Throughput	57	✓	✓	✓	✓
Get Rate	30	✓	✓	✓	✓	Set Voltage	58	✓	✓	✓	✓
Get Settings	31	✓	✓	✓	✓	Set Weight Units	59	✓	✓	✓	✓
Get Star (*) Function Value	33	✓	✓	✓	✓	Set Yield	60	✓	✓	✓	✓
Get Status	34	✓	✓	✓	✓	Silence Alarm	61	✓	✓	✓	✓
Get Steady State Rate	36	✓	✓	✓	✓	Start / Stop / Status	62	✓	✓	✓	✓
Get Target Throughput & Status	37	✓	✓	✓	✓	Stop Cycle / Stop Retry	63	✓	✓	✓	✓
Get Totals	38	✓	✓	✓	✓	Save / Restore Settings	64		✓		
Get Type	40	✓	✓	✓	✓	End Empty, End Full	65		✓		
Get Version	41	✓	✓	✓	✓	Extra Bin Dump	66		✓		
Get Weight Units	42	✓	✓	✓	✓	Precision Ratio	67		✓		
Get Yield	43	✓	✓	✓	✓						

Abort Cycle or Retry

Description: Aborts the current cycle or aborts the current cycle retry, then continues on to the next cycle when ready. Invalid for LIW controllers.

Command Format

Field #	Name	Size	Range	Description
1	Address	1	0 to 255	Address of the controller
2	Command Code	1	27	Command
3	Abort Command	1	1 or 2	1 = Abort Cycle, 2 = Abort Retry
4	Checksum	1	0 to 255	Checksum
Total		4		

Response Format

Field #	Name	Size	Range	Description
1	Address	1	0 to 255	Address of the controller
2	Response Code	1	48	Response Code
3	ACK/NAK	1	6 or 21	6-ACK, 21=NAK
	Checksum	1	0 to 255	Checksum
Total		4		

Clear Totals

Description: Resets the totals to zero.

Command Format

Field #	Name	Size	Range	Description
1	Address	1	0 to 255	Address of the controller
2	Command Code	1	24	Command
3	Checksum	1	0 to 255	Checksum
Total		3		

Response Format

Field #	Name	Size	Range	Description
1	Address	1	0 to 255	Address of the controller
2	Response Code	1	48	Response Code
3	ACK/NAK	1	6 or 21	6-ACK, 21=NAK
	Checksum	1	0 to 255	Checksum
Total		4		

NOTE: The totals will not be erased until the end of the current cycle. If the blender is idle, the totals will be cleared at the end of the next cycle.

Clear Totals Immediately

Description: Resets the totals to zero.

Command Format

Field #	Name	Size	Range	Description
1	Address	1	0 to 255	Address of the controller
2	Command Code	1	28	Command
3	Checksum	1	0 to 255	Checksum
Total		3		

Response Format

Field #	Name	Size	Range	Description
1	Address	1	0 to 255	Address of the controller
2	Response Code	1	48	Response Code
3	ACK/NAK	1	6 or 21	6-ACK, 21=NAK
	Checksum	1	0 to 255	Checksum
Total		4		

NOTE: The totals will be erased immediately for all components. Erases component 12 for LIW.

Get Address

Description: Returns the address of the controller.

Command Format

Field #	Name	Size	Range	Description
1	Address	1	0 to 255	Address of the controller
2	Command Code	1	54	Command
3	Checksum	1	0 to 255	Checksum
Total		3		

Response Format

Field #	Name	Size	Range	Description
1	Address	1	0 to 255	Address of the controller
2	Response Code	1	54	Response Code
3	Pad	1	0	Padding always zero
4	ID	1	0 - 255	Address / ID of controller
5	Baud Rate	1	1	1=1200 baud
6	Checksum	1	0 to 255	Checksum
Total		6		

Get All Parameters

Description: Returns all of the parameters and their current values.

Command Format

Field #	Name	Size	Range	Description
1	Address	1	0 to 255	Address of the controller
2	Command Code	1	22	Command
3	Sequence #	2	1-65,536	See Appendix B
4	Checksum	1	0 to 255	Checksum
Total		5		

Response Format

Field #	Name	Size	Range	Description
1	Address	1	0 to 255	Address of the controller
2	Response Code	1	22	Response Code
3	Sequence #	2	1-65,536	See Appendix B
4	Packet	32	Each byte 0 - 255	See Appendix B
5	Checksum	1	0 to 255	Checksum
Total		37		

NOTE: Parameters are given in the WSB or LIW manual. A three letter acronym that begins with an underscore (_) should be replaced with a binary # between 1 and 12. This number corresponds to the component #.

Get Batch Info

Description: Returns the batch weight, current portion, accumulated total, and batch count.

Command Format

Field #	Name	Size	Range	Description
1	Address	1	0 to 255	Address of the controller
2	Command Code	1	84	Command
3	Checksum	1	0 to 255	Checksum
Total		3		

Response Format

Field #	Name	Size	Range	Description
1	Address	1	0 to 255	Address of the controller
2	Response Code	1	84	Response Code
3	Batch Weight	2	0-65,536	Batch weight (pounds or kilograms only) (see "Get Weight Units" command for units) See note 1
4	Current Portion	2	0-65,536	Completed portion of the current batch
5	Accumulative Total	2	0-65,536	Total weight of all completed batches
6	Batch Count	2	0-65,536	Total number of completed batches
7	Checksum	1	0 to 255	Checksum
Total		11		

Note 1: Batch weight is given in pounds if "Get Weight Units" returns either pounds or ounces. If "Get Weight Units" returns either kilograms or grams, then batch weight is in kilograms.

Get Cycle Weight and Time

Description: Returns the size of the last batch/cycle and the duration of time between the last two cycles.

Command Format

Field #	Name	Size	Range	Description
1	Address	1	0 to 255	Address of the controller
2	Command Code	1	50	Command
3	Checksum	1	0 to 255	Checksum
Total		3		

Response Format

Field #	Name	Size	Range	Description
1	Address	1	0 to 255	Address of the controller
2	Response Code	1	50	Response Code
3	Cycle Weight	2	0-65,536	Grams (or tenths of grams) in last cycle
4	Cycle Time	4	0-4,294,967,295	Number of interrupts during the last cycle (244/sec)
5	Checksum	1	0 to 255	Checksum
Total		9		

Get Cycle Weight and Time (4 byte)

Description: Returns the size of the last batch/cycle and the duration of time between the last two cycles. This is an updated version of command 50 with a 4 byte Cycle Weight.

Command Format

Field #	Name	Size	Range	Description
1	Address	1	0 to 255	Address of the controller
2	Command Code	1	79	Command
3	Checksum	1	0 to 255	Checksum
Total		3		

Response Format

Field #	Name	Size	Range	Description
1	Address	1	0 to 255	Address of the controller
2	Response Code	1	79	Response Code
3	Cycle Weight	4	0-4,294,967,295	Grams (or tenths of grams) in last cycle
4	Cycle Time	4	0-4,294,967,295	Number of interrupts during the last cycle (244/sec)
5	Checksum	1	0 to 255	Checksum
Total		11		

Get Cycle Info

Description: Returns the end-of-cycle information from the last completed cycle. This data is the same data used to generate the end-of-cycle *54 report in 12-12 and 4088 Standard controllers and the Live Diagnostics data in 4088 Touchscreen controllers. (introduced in firmware released after T0120A, January 2020).

Command Format

Field #	Name	Size	Range	Description
1	Address	1	0 to 255	Address of the controller
2	Command Code	1	91	Command
	Packet			
3	Checksum	1	0 to 255	Checksum
	Total	3		

Response Format

Field #	Name	Size	Range	Description
1	Address	1	0 to 255	Address of the controller
2	Response Code	1	50	Response Code
3	Cycle Weight	2	0-65,536	Grams (or tenths of grams) in last cycle
4	Cycle Time	4	0-4,294,967,295	Number of interrupts during the last cycle (244/sec)
5	Checksum	1	0 to 255	Checksum
	Total	9		

Get Display

Description: Returns the current display buffer. (Valid in LIW).

Command Format

Field #	Name	Size	Range	Description
1	Address	1	0 to 255	Address of the controller
2	Command Code	1	56	Command
3	Checksum	1	0 to 255	Checksum
	Total	3		

Response Format

Field #	Name	Size	Range	Description
1	Address	1	0 to 255	Address of the controller
2	Response Code	1	56	Response Code
3	Display	8	ASCII	ASCII character currently on display Most significant byte is the leftmost character
5	Checksum	1	0 to 255	Checksum
	Total	11		

Get Display Extended

Description: Returns the current display buffer. This command returns WSB 12-12 controller's 40-character display. Valid in LIW and 12-12 WST controllers.

Command Format

Field #	Name	Size	Range	Description
1	Address	1	0 to 255	Address of the controller
2	Command Code	1	112	Command
3	Checksum	1	0 to 255	Checksum
Total		3		

Response Format

Field #	Name	Size	Range	Description
1	Address	1	0 to 255	Address of the controller
2	Response Code	1	112	Response Code
3	Display	40	ASCII	ASCII character currently on display Most significant byte is the leftmost character
5	Checksum	1	0 to 255	Checksum
Total		43		

Get Linespeed and Error Accumulators

Description: Retrieves the Linespeed target and error accumulators from the controller.
Valid in LIW. Not Valid in 12-12/N controllers.

Command Format

Field #	Name	Size	Range	Description
1	Address	1	0 to 255	Address of the controller
2	Command Code	1	61	Command
3	Checksum	1	0 to 255	Checksum
Total		3		

Response Format

Field #	Name	Size	Range	Description
1	Address	1	0 to 255	Address of the controller
2	Response Code	1	61	Response Code
3	Linespeed Target	2	0-65,536	Pulses per second
4	Accumulated Time (TTM)	2	0-65,536	See Note 1
5	Accumulated Counts (TPU)	4	0-4,294,967,295	See Note 2
6	Checksum	1	0 to 255	Checksum
Total		11		

Note 1: Target time is the accumulated time in seconds that the target has been held since the last adjustment.

Note 2: Accumulated Counts are the number of counts (pulses) per second.

Get Extrusion Control Mode

Description: Retrieves the Extrusion Control Mode.
Valid in LIW.

Command Format

Field #	Name	Size	Range	Description
1	Address	1	0 to 255	Address of the controller
2	Command Code	1	60	Command
3	Checksum	1	0 to 255	Checksum
Total		3		

Response Format

Field #	Name	Size	0 to 255	Description
1	Address	1	0 to 255	Address of the controller
2	Response Code	1	60	Response code
3	System Type	1	2 or 9	Grams (or tenths of grams)
4	Extrusion Mode	1	0-5	See note 1
5	Checksum	1	0 to 255	Checksum
	Total		5	

Note 1 - Extrusion Mode

BIT	Name	Value	Description
4	Extrusion control	0 = off	
		1 = RATE	
		2 = EX CTRL	
		3 = CTRL X	See note 2
		4 = CTRL T	See note 3
		5 = CTRL D	See note 4

Note 2: Adjust throughput (extruder speed) to maintain yield.

Note 3: Adjust takeoff to maintain yield.

Note 4: Adjust takeoff to maintain yield while adjusting the extruders' speed to maintain the correct ratio in a multi layer line.

Get Parameter

Description: Gets a single parameter. Valid in LIW however parameters will differ from WSB.

Command Format

Field #	Name	Size	Range	Description
1	Address	1	0 to 255	Address of the controller
2	Command Code	1	69	Command
3	Parameter ID	3	ASCII	Three letter acronym designating parameter.
4	Padding	2	0	Padding always zero
5	Checksum	1	0 to 255	Checksum
	Total		8	

Response Format

Field #	Name	Size	Range	Description
1	Address	1	0 to 255	Address of the controller
2	Response Code	1	69	Response code
3	Parameter Value	2	0-65,536	The value of the parameter.
4	Checksum	1	0 to 255	Checksum
	Total		5	

NOTE: Parameters are given in the WSB manual. A three letter acronym that begins with an underscore (_) should be replaced with a binary # between 1 and 12. This number corresponds to the component #.

Get Rate

Description: Gets the downstream equipment rate and the counts per length setting.
Valid in LIW.

Command Format

Field #	Name	Size	Range	Description
1	Address	1	0 to 255	Address of the controller
2	Command Code	1	57	Command
3	Checksum	1	0 to 255	Checksum
		Total	3	

Response Format

Field #	Name	Size	0 to 255	Description
1	Address	1	0 to 255	Address of the controller
2	Response Code	1	57	Response code
3	Rate	2	0-65536	Pulses per second
4	CPL	2	0-65536	Counts per length (foot or Meter). See note 1
5	Checksum	1	0 to 255	Checksum
		Total	7	

Note 1: If get weight units returns pounds or ounces, the length is feet.
If get weight units returns kilograms or grams, the length is meters.
See "Get Weight Units" for more information.

Get Settings

Description: Returns the mix percentages, component types, work order #, and operator #.

Command Format (type 1 - Four Component Software)

Field #	Name	Size	Range	Description
1	Address	1	0 to 255	Address of the controller
2	Command Code	1	20	Command
3	Checksum	1	0 to 255	Checksum
Total		3		

Response Format Type 1 - Four Component Software

Field #	Name	Size	Range	Description
1	Address	1	0 to 255	Address of the controller
2	Response Code	1	20	Response Code
3	System Type	1	2,3,9,10	2=tenths of grams, also, NO change in totals since last get total cmd (16) 3=tenths of grams, also, change in totals since last get total cmd (16) 9=grams, also, NO change in totals since last get total cmd (16) 10=grams, also, change in totals since last get total cmd (16)
4	Software Type	1	4	4=four component software
5	Type Hopper 1	1	0	Always zeros (implied 1=regrind)
6	Setting Hopper 1	2	0 to 999	Implied decimal point ##.#
7	Pad 2	3	0	Padding always zero
8	Type Hopper 4	1	0	always zeros (implied 3=color)
9	Setting Hopper 4	2	0 to 999	Implied decimal point ##.#
10	Type Hopper 3	1	0	always zeros (implied 3=additive)
11	Setting Hopper 3	2	0 to 999	Implied decimal point ##.#
12	Pad 5-12	24	0	Padding always zero
13	Recipe Number	2	100 to 65,536	Recipe Number
14	Operator Number	2	0 to 999	Operator Number
15	Work Order Number	4	0 to 999,999	Work Order Number
16	Checksum	1	0 to 255	Checksum
Total		49		

Response Format Type 2 - Twelve Component Software

Field #	Name	Size	Range	Description
1	Address	1	0 to 255	Address of the controller
2	Response Code	1	20	Response Code
3	System Type	1	2,3,9,10	2=tenths of grams, also, NO change in totals since last get total cmd (16) 3=tenths of grams, also, change in totals since last get total cmd (16) 9=grams, also, NO change in totals since last get total cmd (16) 10=grams, also, change in totals since last get total cmd (16)
4	Software Type	1	12	12=Twelve component software
5	Type Hopper 1	1	0 to 3	1=regrind, 2=natural, 3=additive/color, 0=none
6	Setting Hopper 1	2	0 to 999	Implied decimal point r/a ##.# or n ###
7	Type Hopper 2	1	0 to 3	Always zeros (implied 1=regrind)
8	Setting Hopper 2	2	0 to 999	Implied decimal point ##.#

9	Type Hopper 3	1	0 to 3	always zeros (implied 3=color)
10	Setting Hopper 3	2	0 to 999	Implied decimal point ##.#
11	Type Hopper 4	1	0 to 3	always zeros (implied 3=additive)
12	Setting Hopper 4	2	0 to 999	Implied decimal point ##.#
13	Type Hopper 5	1	0 to 3	1=regrind, 2=natural, 3=additive/color, 0=none
14	Setting Hopper 5	2	0 to 999	Implied decimal point r/a ##.# or n ###
15	Type Hopper 6	1	0 to 3	1=regrind, 2=natural, 3=additive/color, 0=none
16	Setting Hopper 6	2	0 to 999	Implied decimal point r/a ##.# or n ###
17	Type Hopper 7	1	0 to 3	1=regrind, 2=natural, 3=additive/color, 0=none
18	Setting Hopper 7	2	0 to 999	Implied decimal point r/a ##.# or n ###
19	Type Hopper 8	1	0 to 3	1=regrind, 2=natural, 3=additive/color, 0=none
20	Setting Hopper 8	2	0 to 999	Implied decimal point r/a ##.# or n ###
21	Type Hopper 9	1	0 to 3	1=regrind, 2=natural, 3=additive/color, 0=none
22	Setting Hopper 9	2	0 to 999	Implied decimal point r/a ##.# or n ###
23	Type Hopper 10	1	0 to 3	1=regrind, 2=natural, 3=additive/color, 0=none
24	Setting Hopper 10	2	0 to 999	Implied decimal point r/a ##.# or n ###
25	Type Hopper 11	1	0 to 3	1=regrind, 2=natural, 3=additive/color, 0=none
26	Setting Hopper 11	2	0 to 999	Implied decimal point r/a ##.# or n ###
27	Type Hopper 12	1	0 to 3	1=regrind, 2=natural, 3=additive/color, 0=none
28	Setting Hopper 12	2	0 to 999	Implied decimal point r/a ##.# or n ###
29	Recipe Number	2	100 to 65,536	Recipe Number
30	Operator Number	2	0 to 999	Operator Number
31	Work Order Number	4	0 to 999,999	Work Order Number
32	Checksum	1	0 to 255	Checksum
	Total	49		

Get Star Function Value

Description: Gets the value of the star (*) function. Currently, only *52 and *82 are enabled.

Command Format

Field #	Name	Size	Range	Description
1	Address	1	0 to 255	Address of the controller
2	Command Code	1	71	Command
3	Reserved	1	0	Reserved for future use
4	Checksum	1	0 to 255	Checksum
		Total	4	

Response Format

Field #	Name	Size	0 to 255	Description
1	Address	1	0 to 255	Address of the controller
2	Response Code	1	71	Response code
3	Star Function Code	1	130	130 = *82 in packed BCD format
4	*82 Value	1	0-12	
5	Star Function Code	1	82	82 = *52 in packed BCD format
6	*52 Value	1	0-1	
7	Reserved	16	0	Reserved for future use
23	Checksum	1	0 to 255	Checksum
		Total	23	

Get Status

Description: Returns the current state of all signal inputs and outputs.

Command Format

Field #	Name	Size	Range	Description
1	Address	1	0 to 255	Address of the controller
2	Command Code	1	53	Command
3	Checksum	1	0 to 255	Checksum
Total		3		

Response Format

Field #	Name	Size	Range	Description
1	Address	1	0 to 255	Address of the controller
2	Response Code	1	53	Response code
3	Output Status	2	0 to 65535	See note 1
4	Alarm Status	1	0 to 255	See note 2
5	Sensor Status	1	0 to 255	See note 3
6	Checksum	1	0 to 255	Checksum
Total		7		

Note 1a - Output status for FOUR component software

BIT	Name	Value	Description
0	Mixer Valve	1=open 0=closed	Rightmost bit
1	Reserved	1=open 0=closed	
2	Reserved	1=open 0=closed	
3	Reserved	1=open 0=closed	
4	Reserved	1=open 0=closed	
5	Reserved	1=open 0=closed	
6	Reserved	1=open 0=closed	
7	Reserved	1=open 0=closed	
8	Mix Motor	1=open 0=closed	
9	Alarm	1=open 0=closed	
10	Weigh Bin Valve	1=open 0=closed	
11	Additive	1=open 0=closed	
12	Color	1=open 0=closed	
13	Natural	1=on 0=off	
14	Regrind	1=open 0=closed	
15	Reserved	1=on 0=off	Leftmost bit

Note 1b - Output status for TWELVE component software

BIT	Name	Value	Description
0	Component 1	1=open 0=closed	Rightmost bit
1	Component 2	1=open 0=closed	
2	Component 3	1=open 0=closed	
3	Component 4	1=open 0=closed	
4	Component 5	1=open 0=closed	

5	Component 6	1=open 0=closed	
6	Component 7	1=open 0=closed	
7	Component 8	1=open 0=closed	
8	Component 9	1=open 0=closed	
9	Component 10	1=open 0=closed	
10	Component 11	1=open 0=closed	
11	Component 12	1=open 0=closed	
12	Weigh Bin Valve	1=open 0=closed	
13	Mix Motor	1=on 0=off	
14	Mixer Valve	1=open 0=closed	
15	Alarm	1=on 0=off	Leftmost bit

Note 2 - Alarm Status

BIT	Name	Value	Description
0 to 6	Alarm Code	1 to 12 = Component alarm	Bit 0 is the rightmost bit
		13 = Batch Alarm	
		14 = Bail Out Alarm	
		15 = Dump Alarm	
		16 = No Pulse Alarm	
		17 = XUL Limit Alarm	
		18 = MAX. Voltage, XCV	
		19 = Max. Voltage, TCV	
		20 = Over Weight Alarm	
		21 = Wait For Recipe Alarm	
		22 = Weight Drop Alarm	
		23 = MCT Parameter Alarm	
		24 = Alternate Color Alarm	
		25 = Mix Off Alarm	
		26 = G2F Parameter Alarm	
		27 = Zero Rate Alarm (LIW only)	
		28 = No Fill Alarm (LIW only)	
		29 = Zero Weight Alarm (LIW only)	
		33 = Flow Control Alarm	
		34 = Component / Valve Leak Alarm	
7	Alarm Silenced	1 = silenced	Leftmost bit

Note 3 - Sensor Status

BIT	Name	Value	Description
0	Empty mix chamber sensor	1=yes 0=no	Rightmost bit
1	Reserved		
2	Silence alarm switch	1=yes 0=no	
3	Immediate Pause switch	1=yes 0=no	
4	Manual Mode	1=yes 0=no	
5	Program Mode	1=yes 0=no	
6	Running Mode	1=yes 0=no	
7	Soft Stop Mode *	1=yes 0=no	Leftmost bit

* See Start/Stop/Status command

Get Steady State Rate

Description: Returns throughput rate. Valid in LIW.

Command Format

Field #	Name	Size	Range	Description
1	Address	1	0 to 255	Address of the controller
2	Command Code	1	64	Command
3	Checksum	1	0 to 255	Checksum
Total		3		

Response Format

Field #	Name	Size	Range	Description
1	Address	1	0 to 255	Address of the controller
2	Response Code	1	64	Response code
3	Steady State Rate	4	0 to 4,294,967,295	Grams (or tenths of grams) per hour
4	Checksum	1	0 to 255	Checksum
Total		7		

Get Target Throughput and Status

Description: Returns the target throughput rate for extrusion control.

See XCV parameter in blender manual for more information. Valid in LIW.

Command Format

Field #	Name	Size	Range	Description
1	Address	1	0 to 255	Address of the controller
2	Command Code	1	29	Command
3	Checksum	1	0 to 255	Checksum
Total		3		

Response Format

Field #	Name	Size	Range	Description
1	Address	1	0 to 255	Address of the controller
2	Response Code	1	29	Response code
3	Status	1	0-255	See note 1
4	Steady State Rate	4	0 to 4,294,967,295	Grams (or tenths of grams) per hour
5	Checksum	1	0 to 255	Checksum
Total		8		

Note 1 - Status

BIT	Name	Value	Description
0	Extrusion control	1=on 0=off	Bit 0 is the rightmost bit
1		1=steady 0=not steady	T or no T on display
2		1=Thruput 0=Voltage	Controlling mode
3		1=Grs 0=Tenths of Grs	Weight unit of rate
4		1=Yield 0=Weight	See note 2
5 - 7	Reserved		Leftmost bit

Note 2: If the extrusion process is being controlled by weight, then the output will be a steady weight per time (e.g. lbs/hr). If however the extrusion process is being controlled by yield, then the output will be a steady weight per length (e.g. lbs/foot).

Get Totals

Description: Returns the current totals. LIW see Note 4.

Command Format

Field #	Name	Size	Range	Description
1	Address	1	0 to 255	Address of the controller
2	Command Code	1	16 or 17	See Note 2
3	Checksum	1	0 to 255	Checksum
		Total	3	

Response Format Type 1 - Four Component Software

Field #	Name	Size	Range	Description
1	Address	1	0 to 255	Address of the controller
2	Response Code	1	16 or 17	See Note 2
3	System Type	1	2 or 9	2=tenths of grams, 9=grams
4	Software Type	1	4	4=four component software
5	Sequence Number	2	0	Reserved for future use
6	Cycles	2	0 to 65535	Number of batches that have been made
7	Clear/Turnovers Flags	2	0 to 65535	See note 1
8	Total Hopper 1	4	0 to 4,294,967,295	Grams (or tenths of grams) used
9	Total Hopper 2	4	0 to 4,294,967,295	Grams (or tenths of grams) used
10	Total Hopper 3	4	0 to 4,294,967,295	Grams (or tenths of grams) used
11	Total Hopper 4	4	0 to 4,294,967,295	Grams (or tenths of grams) used
12	Pad 5-12	32	0	Padding always zero
13	Checksum	1	0 to 255	Checksum
		Total	59	

Response Format Type 2 - Twelve Component Software

Field #	Name	Size	Range	Description
1	Address	1	0 to 255	Address of the controller
2	Response Code	1	16 or 17	See Note 2
3	System Type	1	2 or 9	2=tenths of grams, 9=grams
4	Software Type	1	12	12=twelve component software
5	Sequence Number	2	0	Reserved for future use
6	Cycles	2	0 to 65535	Number of batches that have been made
7	Clear/Turnovers Flags	2	0 to 65535	See note 1
8	Total Hopper 1	4	0 to 4,294,967,295	Grams (or tenths of grams) used
9	Total Hopper 2	4	0 to 4,294,967,295	Grams (or tenths of grams) used
10	Total Hopper 3	4	0 to 4,294,967,295	Grams (or tenths of grams) used
11	Total Hopper 4	4	0 to 4,294,967,295	Grams (or tenths of grams) used
12	Total Hopper 5	4	0 to 4,294,967,295	Grams (or tenths of grams) used
13	Total Hopper 6	4	0 to 4,294,967,295	Grams (or tenths of grams) used
14	Total Hopper 7	4	0 to 4,294,967,295	Grams (or tenths of grams) used
15	Total Hopper 8	4	0 to 4,294,967,295	Grams (or tenths of grams) used
16	Total Hopper 9	4	0 to 4,294,967,295	Grams (or tenths of grams) used
17	Total Hopper 10	4	0 to 4,294,967,295	Grams (or tenths of grams) used
18	Total Hopper 11	4	0 to 4,294,967,295	Grams (or tenths of grams) used
19	Total Hopper 12	4	0 to 4,294,967,295	Grams (or tenths of grams) used
20	Checksum	1	0 to 255	Checksum
		Total	59	

Response Format Type 3 - No Totals Available

Field #	Name	Size	Range	Description
1	Address	1	0 to 255	Address of the controller
2	Response Code	1	32 or 34	See note 3
3	Checksum	1	0 to 255	Checksum
Total		3		

Note 1 - Flag

This field was implement in chips 10612 or later

BIT	Name		Description
0	Totals Turnover Flag	1=on 0=off	1 = cycle counter turned over
1		1=on 0=off	1 = total for component 1 turned over
2		1=on 0=off	1 = total for component 2 turned over
3		1=on 0=off	1 = total for component 3 turned over
4		1=on 0=off	1 = total for component 4 turned over
5		1=on 0=off	1 = total for component 5 turned over
6		1=on 0=off	1 = total for component 6 turned over
7		1=on 0=off	1 = total for component 7 turned over
8		1=on 0=off	1 = total for component 8 turned over
9		1=on 0=off	1 = total for component 9 turned over
10		1=on 0=off	1 = total for component 10 turned over
11		1=on 0=off	1 = total for component 11 turned over
12		1=on 0=off	1 = total for component 12 turned over
13		1=on 0=off	1 = all component totals, cycle count cleared
14	not used		
15	not used		

Note 2: If the "Command Code" is set to 16, the controller will reset an internal flag indicating that the totals have been received. If, however, "Command Code" is set to 17, the flag will NOT be reset. See the "System Type" part of the "Get Settings" command for how the internal flag is used.

Note 3: Response code 32 is used with command code 16 and response code 34 is used with command code 17.

Note 4: LIW controller response is the same as 12 Component Software response and the totals for the single LIW component is stored in hopper 12.

Get Type

Description: Returns the software type (4 or 12) and load cell type (2 or 9), (tenths of grams or whole grams).

Command Format

Field #	Name	Size	Range	Description
1	Address	1	0 to 255	Address of the controller
2	Command Code	1	49	Command
3	Checksum	1	0 to 255	Checksum
		Total	3	

Response Format

Field #	Name	Size	0 to 255	Description
1	Address	1	0 to 255	Address of the controller
2	Response Code	1	49	Response code
3	System Type	1	2 or 9	2=tenths of grams, 9=grams
4	Software Type	1	4 or 12	4=four component software 12=twelve component software
5	Checksum	1	0 to 255	Checksum
		Total	5	

Get Version

Description: Returns the version of the software in the controller. Valid for LIW.

Command Format

Field #	Name	Size	Range	Description
1	Address	1	0 to 255	Address of the controller
2	Command Code	1	80	Command
3	Checksum	1	0 to 255	Checksum
	Total	3		

Response Format

Field #	Name	Size	Range	Description
1	Address	1	0 to 255	Address of the controller
2	Response Code	1	80	Response code
3	Version Number	6	ASCII	Software version number (ASCII)
4	Checksum	1	0 to 255	Checksum
	Total	9		

Get Weight Units

Description: Returns the units that the blender is using to display totals, such as pounds or kilograms. This command is needed to interpret the Get Batch Info command.
Not Valid in LIW.

Command Format

Field #	Name	Size	Range	Description
1	Address	1	0 to 255	Address of the controller
2	Command Code	1	85	Command
3	Checksum	1	0 to 255	Checksum
	Total	3		

Response Format

Field #	Name	Size	0 to 255	Description
1	Address	1	0 to 255	Address of the controller
2	Response Code	1	85	Response code
3	Weight units	1	0, 1, 2, or 4	0=pounds, 1=ounces, 2=grams, 4=kilograms
4	Checksum	1	0 to 255	Checksum
	Total	4		

Get Yield

Description: Returns the target Yield for extrusion control.
See XCV parameter in blender manual for more information.

Command Format

Field #	Name	Size	Range	Description
1	Address	1	0 to 255	Address of Controller
2	Command Code	1	31	Command
3	Checksum	1	0 to 255	Checksum
	Total	3		

Response Format

Field #	Name	Size	Range	Description
1	Address	1	0 to 255	Address of Controller
2	Response Code	1	31	Response Code
3	Status	1	0-255	See note 1
4	Target Yield	2	0 to 65,536	Grams (or tenths of grams)
5	Checksum	1	0 to 255	Checksum
	Total	6		

Note 1 - Status

BIT	Name	Value	Description
0	Extrusion control	1=on 0=off	Bit 0 is the rightmost bit
1		1=steady 0=not steady	T or no T on display
2 - 7	Reserved		Leftmost bit

Note 2: If the extrusion process is being controlled by weight, then the output will be a steady weight per time (e.g. lbs/hr). If however the extrusion process is being controlled by yield, then the output will be a steady weight per length (e.g. lbs/foot).

Send Keystroke

Description: Sends a keystroke. (See "Set Remote Keypad" command).
Valid in LIW. Not valid in Touchscreen or MGF.

Command Format

Field #	Name	Size	Range	Description
1	Address	1	0 to 255	Address of the controller
2	Command Code	1	87	Command
3	Code	1	ASCII	See note 1
4	Checksum	1	0 to 255	Checksum
	Total	4		

Response Format

Field #	Name	Size	Range	Description
1	Address	1	0 to 255	Address of the controller
2	Response Code	1	48	Response code
3	ACK/NAK	1	6 or 21	6=ack, 21=nak
4	Checksum	1	0 to 255	Checksum
	Total	4		

Note 1:

<u>KEY</u>	<u>CODE</u>	<u>KEY</u>	<u>CODE</u>
VIEW	Q	*	*
RECP	h	0	0
BTCH	H	CE	X
FAST	I	HOLD	M
EXIT	E	DUMP	D
SET	S	PARA	K
OPER	O	ZERO	Z
TIME	T	FULL	F
CAL	L	MIX	G
TAG	e	ALRM	k
REG	R		
1	1		
2	2		
3	3		
NAT / A	A		
4	4		
5	5		
6	6		
COL / B	B		
7	7		
8	8		
9	9		
ADD / C	C		

Send Settings

Description: Sets the mix percentages, component types, work order #, and operator #.
Not valid in LIW controllers.

Command Format Type 1 - Four Component Software

Field #	Name	Size	Range	Description
1	Address	1	0 to 255	Address of the controller
2	Command Code	1	19	Command
3	Type Hopper 1	1	1	Always 1=regrind
4	Setting Hopper 1	2	0 to 999	Implied decimal point ###
5	Type Hopper 2	1	2	Always 2=natural
6	Setting Hopper 2	2	100	Always on
7	Type Hopper 4	1	3	Always 3=color
8	Setting Hopper 4	2	0 to 999	Implied decimal point ###
9	Type Hopper 3	1	3	Always 3=additive
10	Setting Hopper 3	2	0 to 999	Implied decimal point ###
11	Padding	24	0	Padding always zero
12	Recipe number	2	100 to 65,536	Recipe number
13	Work Order Number	3	0 to 999,999	Work order number
14	Operator number	2	0 to 999	Operator number
15	Checksum	1	0 to 255	Checksum
		Total	46	

Command Format Type 2 - Twelve Component Software

Field #	Name	Size	Range	Description
1	Address	1	0 to 255	Address of the controller
2	Command Code	1	19	Command
3	Type Hopper 1	1	0 to 3	1=regrind, 2=natural, 3=additive/color, 0=none
4	Setting Hopper 1	2	0 to 999	Implied decimal point r/a ### or n ###
5	Type Hopper 2	1	0 to 3	1=regrind, 2=natural, 3=additive/color, 0=none
6	Setting Hopper 2	2	0 to 999	Implied decimal point r/a ### or n ###
7	Type Hopper 3	1	0 to 3	1=regrind, 2=natural, 3=additive/color, 0=none
8	Setting Hopper 3	2	0 to 999	Implied decimal point r/a ### or n ###
9	Type Hopper 4	1	0 to 3	1=regrind, 2=natural, 3=additive/color, 0=none
10	Setting Hopper 4	2	0 to 999	Implied decimal point r/a ### or n ###
11	Type Hopper 5	1	0 to 3	1=regrind, 2=natural, 3=additive/color, 0=none
12	Setting Hopper 5	2	0 to 999	Implied decimal point r/a ### or n ###
13	Type Hopper 6	1	0 to 3	1=regrind, 2=natural, 3=additive/color, 0=none
14	Setting Hopper 6	2	0 to 999	Implied decimal point r/a ### or n ###
15	Type Hopper 7	1	0 to 3	1=regrind, 2=natural, 3=additive/color, 0=none
16	Setting Hopper 7	2	0 to 999	Implied decimal point r/a ### or n ###
17	Type Hopper 8	1	0 to 3	1=regrind, 2=natural, 3=additive/color, 0=none
18	Setting Hopper 8	2	0 to 999	Implied decimal point r/a ### or n ###
19	Type Hopper 9	1	0 to 3	1=regrind, 2=natural, 3=additive/color, 0=none
20	Setting Hopper 9	2	0 to 999	Implied decimal point r/a ### or n ###
21	Type Hopper 10	1	0 to 3	1=regrind, 2=natural, 3=additive/color, 0=none
22	Setting Hopper 10	2	0 to 999	Implied decimal point r/a ### or n ###

Command Format Type 2 - Twelve Component Software (Continued)

Field #	Name	Size	Range	Description
23	Type Hopper 11	1	0 to 3	1=regrind, 2=natural, 3=additive/color, 0=none
24	Setting Hopper 11	2	0 to 999	Implied decimal point r/a ##.# or n ###
25	Type Hopper 12	1	0 to 3	1=regrind, 2=natural, 3=additive/color, 0=none
26	Setting Hopper 12	2	0 to 999	Implied decimal point r/a ##.# or n ###
27	Recipe number	2	100 to 65,536	Recipe number
28	Work Order Number	3	0 to 999,999	Work order number
29	Operator number	2	0 to 999	Operator number
30	Checksum	1	0 to 255	Checksum
	Total	46		

Response Format

Field #	Name	Size	Range	Description
1	Address	1	0 to 255	Address of the controller
2	Response Code	1	48	Response code
3	ACK/NAK	1	6 or 21	6=ack, 21=nak
4	Checksum	1	0 to 255	Checksum
	Total	4		

Set Batch Weight

Description: Sets the batch flag parameter and the batch weight.
Not valid in LIW.

Command Format

Field #	Name	Size	Range	Description
1	Address	1	0 to 255	Address of the controller
2	Command Code	1	83	Command
3	Batch Weight	2	0 to 65,536	Batch weight (pounds or kilograms only) (see "Get Weight Units" command for units)
				See note 2
4	Flag	1	0,1, or 2	0=no batch, 1=alarm & stop, 2=alarm & cont.
				See note 1
5	Checksum	1	0 to 255	Checksum
	Total	6		

Response Format

Field #	Name	Size	Range	Description
1	Address	1	0 to 255	Address of the controller
2	Response Code	1	48	Response code
3	ACK/NAK	1	6 or 21	6=ack, 21=nak
4	Checksum	1	0 to 255	Checksum
	Total	4		

Note 1: A flag of 0 means to stop running batches. A flag of 1 means to sound the alarm and stop running at the end of the batch. A flag of 2 means to sound the alarm but continue running at the end of the batch.

Note 2: Batch weight is given in pounds if "Get Weight Units" returns either pounds or ounces. If "Get Weight Units" returns either kilograms or grams, then batch weight is in kilograms.

Set Date and Time

Description: Sets the date and time for a particular blender. If the address is 0, all WSB are set with the new date and time and NO response is sent back.

Valid in LIW.

Command Format

Field #	Name	Size	Range	Description
1	Address	1	0 to 255	Address of the controller
2	Command Code	1	81	Command
3	Date and Time	8	See note 1	See note 1
4	Checksum	1	0 to 255	Checksum
		Total	11	

Note 1 - Date and Time

Bit #	Name	Size	Range	Description
0 to 7	Padding		0	
8 to 11	Seconds (ones place)		0 to 9	yy/mm/dd hh:mm:s S
12 to 14	Seconds (tens place)		0 to 5	yy/mm/dd hh:mm: Ss
15	Padding		0	
16 to 19	Minutes (ones place)		0 to 9	yy/mm/dd hh:m M :ss
20 to 22	Minutes (tens place)		0 to 5	yy/mm/dd hh: Mm :ss
23	Padding		0	
24 to 27	Hours (ones place)		0 to 9	yy/mm/dd h H :mm:ss
28 to 29	Hours (tens place)		0 to 2	yy/mm/dd Hh :mm:ss
30	Padding		0	
31	One		1	
32 to 34	Day of week		1 to 7	1 = sunday, 2=monday, ..., 7=saturday
35	Padding		0	
36	One		1	
37	Padding		0	
38 to 39	Padding		0	
40 to 43	Day (ones place)		0 to 9	yy/mm/d D hh:mm:ss
44 to 45	Day (tens place)		0 to 3	yy/mm/ Dd hh:mm:ss
46 to 47	Padding		0	
48 to 51	Month (ones place)		0 to 9	yy/m M /dd hh:mm:ss
52	Month (tens place)		0 or 1	yy/ Mm /dd hh:mm:ss
53 to 55	Padding		0	
56 to 59	Year (ones place)		0 to 9	y Y /mm/dd hh:mm:ss
60 to 63	Years (tens place)		0 to 9	Yy /mm/dd hh:mm:ss

Response Format

Field #	Name	Size	Range	Description
1	Address	1	0 to 255	Address of the controller
2	Response Code	1	48	Response code
3	ACK/NAK	1	6 or 21	6=ack, 21=nak
4	Checksum	1	0 to 255	Checksum
		Total	4	

Set Mixer Motor State

Description: Sets the state of the Mixer Motor
Invalid for LIW.

Command Format

Field #	Name	Size	Range	Description
1	Address	1	0 to 255	Address of the controller
2	Command Code	1	66	Command
3	Mixer Motor State	1	0 or 1	0 = Mixer OFF, 1 = Mixer ON
4	Checksum	1	0 to 255	Checksum
Total		4		

Response Format

Field #	Name	Size	Range	Description
1	Address	1	0 to 255	Address of the controller
2	Response Code	1	48	Response code
3	ACK/NAK	1	6 or 21	6=ack, 21=nak
4	Checksum	1	0 to 255	Checksum
Total		4		

Set Parameter

Description: Sets a single parameter.

Valid in LIW however parameters will differ from WSB.

Command Format

Field #	Name	Size	Range	Description
1	Address	1	0 to 255	Address of the controller
2	Command Code	1	68	Command
3	Parameter ID	3	ASCII	Three letter acronym designating parameter.
4	Parameter Value	2	0 to 65,536	The value of the parameter.
5	Checksum	1	0 to 255	Checksum
Total		8		

Response Format

Field #	Name	Size	Range	Description
1	Address	1	0 to 255	Address of the controller
2	Response Code	1	48	Response code
3	ACK/NAK	1	6 or 21	6=ack, 21=nak
4	Checksum	1	0 to 255	Checksum
Total		4		

NOTE: Parameters are given in the WSB manual. A three letter acronym that begins with an underscore (_) should be replaced with a binary # between 1 and 12. This number corresponds to the component #.

Set Pause Cycle Flag

Description: Pauses the current cycle immediately.

Command Format

Field #	Name	Size	Range	Description
1	Address	1	0 to 255	Address of the controller
2	Command Code	1	25	Command
3	Pause Flag	1	0 or 1	0 = OFF (not paused), 1 = ON (paused)
4	Checksum	1	0 to 255	Checksum
Total		4		

Response Format

Field #	Name	Size	Range	Description
1	Address	1	0 to 255	Address of the controller
2	Response Code	1	48	Response code
3	ACK/NAK	1	6 or 21	6=ack, 21=nak
4	Checksum	1	0 to 255	Checksum
Total		4		

NOTE: This command does the same as using the Immediate Pause toggle on the controller. When this MLAN command is used to pause the cycle immediately, the Immediate Pause toggle on the controller will still function to pause the cycle immediately. If both are set, both will cause the cycle to remain paused until both are set to continue.

Set Rate

Description: Sets a target downstream rate.
Valid in LIW.

Command Format

Field #	Name	Size	Range	Description
1	Address	1	0 to 255	Address of the controller
2	Command Code	1	58	Command
3	Rate	2	0-65536	COUNTS/SEC
4	Checksum	1	0 to 255	Checksum
Total		5		

Response Format

Field #	Name	Size	Range	Description
1	Address	1	0 to 255	Address of the controller
2	Response Code	1	48	Response code
3	ACK/NAK	1	6 or 21	6=ack, 21=nak
4	Checksum	1	0 to 255	Checksum
Total		4		

Set Remote Keypad

Description: Enables or disables the controller's keypad and/or the "Send Keystroke" MLAN command. Valid in LIW. Not valid in the Touchscreen.

Command Format

Field #	Name	Size	Range	Description
1	Address	1	0 to 255	Address of the controller
2	Command Code	1	88	Command
3	FLAG	1	0 or 1	See note 1
4	Checksum	1	0 to 255	Checksum
Total		4		

Response Format

Field #	Name	Size	Range	Description
1	Address	1	0 to 255	Address of the controller
2	Response Code	1	48	Response code
3	ACK/NAK	1	6 or 21	6=ack, 21=nak
4	Checksum	1	0 to 255	Checksum
Total		4		

Note 1: A flag of 0 enables the keypad on the controller and disables the "Send Keystroke" MLAN command. A flag of 1 disables the keypad and enables the command.

Set Steady State Rate

Description: Sets throughput rate. Note however that the blender will continue to reset the rate accordingly to how much material is being consumed. This is useful if you know that the rate just changed, such as in extrusion control, and you don't want to wait until the blender figures it out. Valid in LIW.

Command Format

Field #	Name	Size	30	Description
1	Address	1	0 to 255	Address of the controller
2	Command Code	1	65	Command
3	Steady State Rate	4	0 to 4,294,967,295	Grams (or tenths of grams) per hour
4	Checksum	1	0 to 255	Checksum
Total		7		

Response Format

Field #	Name	Size	Range	Description
1	Address	1	0 to 255	Address of the controller
2	Response Code	1	48	Response code
3	ACK/NAK	1	6 or 21	6=ack, 21=nak
4	Checksum	1	0 to 255	Checksum
Total		4		

Set Star (*) Function

Description: Sets the value of the star function. Invalid for LIW.

Command Format

Field #	Name	Size	Range	Description
1	Address	1	0 to 255	Address of the controller
2	Command Code	1	70	Command
3	Function Number	1	82, 130	Packed BCD Format 82 = *52, 130 = *82
4	Function Value	2	0-1, 0-12	See note 1
5	Checksum	1	0 to 255	Checksum
	Total	6		

Response Format

Field #	Name	Size	Range	Description
1	Address	1	0 to 255	Address of the controller
2	Response Code	1	48	Response code
3	ACK/NAK	1	6 or 21	6=ack, 21=nak
4	Checksum	1	0 to 255	Checksum
		4		

Note 1: If function number is 82 (*52), then the function value is either 0 = off or 1 = on. If the function number is 130 (*82), then the function value is:

0 = off
 1 = component 1,
 2 = component 2,
 3 = component 3,
 4 = component 4,
 5 = component 5,
 6 = component 6,
 7 = component 7,
 8 = component 8,
 9 = component 9,
 10 = component 10,
 11 = component 11,
 12 = component 12

See Blender manual for more information on *52 and *82.

Set Tag

Description: Sets a tag value, either recipe, work order, or operator #. Invalid for LIW.

Command Format

Field #	Name	Size	Range	Description
1	Address	1	0 to 255	Address of the controller
2	Command Code	1	90	Command
3	Tag ID	2	ASCII	Two letter acronym that designates the tag. "RC" = Recipe "WO" = Work Order "OP" = Operator
4	Tag Value	4	0 to 4,294,967,295	The value of the tag. Recipe numbers: 0 to 65,536. Work order numbers: 0 to 999,999. Operator numbers: 0 to 999.
5	Checksum	1	0 to 255	Checksum
		Total	9	

Response Format

Field #	Name	Size	Range	Description
1	Address	1	0 to 255	Address of the controller
2	Response Code	1	48	Response code
3	ACK/NAK	1	6 or 21	6=ack, 21=nak
4	Checksum	1	0 to 255	Checksum
		Total	4	

Set Target Throughput

Description: Sets the Target Throughput for extrusion control.

See XCV parameter in blender manual for more information. Valid in LIW.

Command Format

Field #	Name	Size	Range	Description
1	Address	1	0 to 255	Address of the controller
2	Command Code	1	30	Command
3	Target Throughput	4	0 to 4,294,967,295	
4	Checksum	1	0 to 255	Checksum
	Total	7		

Response Format

Field #	Name	Size	Range	Description
1	Address	1	0 to 255	Address of the controller
2	Response Code	1	48	Response code
3	ACK/NAK	1	6 or 21	6=ack, 21=nak
4	Checksum	1	0 to 255	Checksum
	Total	4		

Set Voltage

Description: Sets a Voltage for downstream equipment. Valid in LIW.

Command Format

Field #	Name	Size	Range	Description
1	Address	1	0 to 255	Address of the controller
2	Command Code	1	59	Command
3	Downstream Voltage	2	0-1000	1000 = 10.00 volts
4	Checksum	1	0 to 255	Checksum
Total		5		

Response Format

Field #	Name	Size	Range	Description
1	Address	1	0 to 255	Address of the controller
2	Response Code	1	48	Response code
3	ACK/NAK	1	6 or 21	6=ack, 21=nak
4	Checksum	1	0 to 255	Checksum
Total		4		

Set Weight Units

Description: Sets the units that the blender uses to display totals, such as pounds or kilograms. Not Valid in LIW.

Command Format

Field #	Name	Size	Range	Description
1	Address	1	0 to 255	Address of the controller
2	Command Code	1	86	Command
3	Weight units	1	0, 1, 2, or 4	0=pounds, 1=ounces, 2=grams, 4=kilograms
4	Checksum	1	0 to 255	Checksum
Total		4		

Response Format

Field #	Name	Size	0 to 255	Description
1	Address	1	0 to 255	Address of the controller
2	Response Code	1	48	Response code
3	ACK/NAK	1	6 or 21	6=ack, 21=nak
4	Checksum	1	0 to 255	Checksum
Total		4		

Set Yield

Description: Sets the Target Yield for extrusion control.
Applies only to blenders in CTRL-X and CTRL-T mode.

Command Format

Field #	Name	Size	Range	Description
1	Address	1	0 to 255	Address of the controller
2	Command Code	1	33	Command
3	Reserved	2	0	Reserved for future use
4	Yield	4	0 to 4,294,967,295	Grams (or tenths of grams) per hour
5	Checksum	1	0 to 255	Checksum
Total		9		

Response Format

Field #	Name	Size	Range	Description
1	Address	1	0 to 255	Address of the controller
2	Response Code	1	48	Response code
3	ACK/NAK	1	6 or 21	6=ack, 21=nak
4	Checksum	1	0 to 255	Checksum
Total		4		

Silence Alarm

Description: Has the same effect as if the silence alarm button was pressed. Valid in LIW.

Command Format

Field #	Name	Size	Range	Description
1	Address	1	0 to 255	Address of the controller
2	Command Code	1	82	Command
3	Checksum	1	0 to 255	Checksum
Total		3		

Response Format

Field #	Name	Size	Range	Description
1	Address	1	0 to 255	Address of the controller
2	Response Code	1	48	Response code
3	ACK/NAK	1	6 or 21	6=ack, 21=nak
4	Checksum	1	0 to 255	Checksum
Total		4		

Start/Stop/Status

Description: Either causes the WSB to stop at the end of the current cycle, start up again, or return its current status. Not valid in LIW.

Command Format

Field #	Name	Size	Range	Description
1	Address	1	0 to 255	Address of the controller
2	Command Code	1	55	Command
3	Subcommand	1	0, 1, or 2	0=mode status, 1=soft stop, 2=soft start
4	Checksum	1	0 to 255	Checksum
	Total	4		

Response Format (Subcommand 1:stop or 2:start)

Field #	Name	Size	Range	Description
1	Address	1	0 to 255	Address of the controller
2	Response Code	1	48	Response code
3	ACK/NAK	1	6 or 21	6=ack, 21=nak
4	Checksum	1	0 to 255	Checksum
	Total	4		

Response Format (Subcommand 0:mode status)

6811, 12-12, 1st gen touchscreen controllers only

Field #	Name	Size	Range	Description
1	Address	1	0 to 255	Address of the controller
2	Response Code	1	55	Response code
3	Mode	1	0, 1, or 2	0=hard stop 1=soft stop 2=automatic mode/running mode
4	Checksum	1	0 to 255	Checksum
	Total	4		

Response Format (Subcommand 0:mode status)

4088 touchscreen controllers only

Field #	Name	Size	Range	Description
1	Address	1	0 to 255	Address of the controller
2	Response Code	1	55	Response code
3	Mode	1	1 - 7	1= Soft Stop - Blender Stopped by Communication 2= Run Mode, Level sensor uncovered (blender is dispensing) 3= Run Mode, Level sensor is covered (stopped by the mix chamber level sensor). 4= Maintenance Mode - Automated Control Lockout enabled at controller via Setup. 5= Power lost, blender stopped. Action required at blender controller to restart. 6= Button stopped, sensor uncovered - STOP button pressed, material demand. 7= Button stopped, sensor covered - STOP button pressed, no material demand.
4	Checksum	1	0 to 255	Checksum
	Total	4		

Stop Cycle / Stop Retry

Description: Either causes the WSB to abort the current cycle or the current dispense.

Aborting the current cycle causes the WSB to start the next cycle.

Aborting the current dispense causes the WSB to start dispensing the next component.

Command Format

Field #	Name	Size	30	Description
1	Address	1	0 to 255	Address of the controller
2	Command Code	1	27	Command
3	Subcommand	1	1 or 2	1 = Stop Cycle; 2 = Stop Retry
4	Checksum	1	0 to 255	Checksum
	Total	4		

Response Format

Field #	Name	Size	Range	Description
1	Address	1	0 to 255	Address of the controller
2	Response Code	1	48	Response code
3	ACK/NAK	1	6 or 21	6=ack, 21=nak
4	Checksum	1	0 to 255	Checksum
	Total	4		

Save or Restore Settings (Touchscreen only)

Description: Saves, restores or factory defaults the Touchscreen controller's current settings. Same as *23 in WSB with the exception of factory default option.

For Touchscreen Controllers only, may require a firmware update.

Command Format

Field #	Name	Size	Range	Description
1	Address	1	0 to 255	Address of the controller
2	Command Code	1	40	Command
	Save/Restore Settings	1	0, 1 or 2	0 = Load Factory Settings 1 = Save User Settings 2 = Restore User Settings
	Checksum	1	0 to 255	Checksum
Total		4		

Response Format

Field #	Name	Size	Range	Description
1	Address	1	0 to 255	Address of the controller
2	Command Code	1	40	Response Code
3	ACK/NAK	1	6 or 21	6-ACK, 21=NAK
	Checksum	1	0 to 255	Checksum
Total		4		

End Empty, End Full (Touchscreen only)

Description: Sets controller to end a cycle when the weigh bin is EMPTY or FULL

For Touchscreen Controllers only, may require firmware update. (Same as *44 in WSB)

Command Format

Field #	Name	Size	Range	Description
1	Address	1	0 to 255	Address of the controller
2	Command Code	1	41	Command
3	Empty, Full, Status	1	0,1 or 2	0 = Get Empty / Full status 1 = End with bin Empty 2 = End with bin Full
4	Checksum	1	0 to 255	Checksum
Total		4		

Response Format (subcommand 1:empty or 2:full)

Field #	Name	Size	Range	Description
1	Address	1	0 to 255	Address of the controller
2	Response Code	1	48	Command
3	ACK/NAK	1	6 or 21	6-ACK, 21=NAK
4	Checksum	1	0 to 255	Checksum
Total		4		

Response Format (subcommand 0:mode status)

Field #	Name	Size	Range	Description
1	Address	1	0 to 255	Address of the controller
2	Response Code	1	48	Command
3	Mode	1	0 or 1	1 = Empty 2 = Full
4	Checksum	1	0 to 255	Checksum
Total		4		

Extra Bin Dump (Touchscreen only)

Description: Weigh Bin Double Dump (Same as *52 in the WSB)

For Touchscreen Controllers only, may require a firmware update.

Command Format

Field #	Name	Size	Range	Description
1	Address	1	0 to 255	Address of the controller
2	Command Code	1	42	Command
3	Dump Once, Dump Twice, Status	1	0,1 or 2	0 = Get Dump status 1 = Dump Once 2 = Dump Twice
4	Checksum	1	0 to 255	Checksum
Total		4		

Response Format (subcommand 1:once or 2:twice)

Field #	Name	Size	Range	Description
1	Address	1	0 to 255	Address of the controller
2	Response Code	1	48	Command
3	ACK/NAK	1	6 or 21	6-ACK, 21=NAK
4	Checksum	1	0 to 255	Checksum
Total		4		

Response Format (subcommand 0:mode status)

Field #	Name	Size	Range	Description
1	Address	1	0 to 255	Address of the controller
2	Response Code	1	42	Response Code
3	Mode	1	1 or 2	1 = Once 2 = Twice
4	Checksum	1	0 to 255	Checksum
Total		4		

Precision Ratio (Touchscreen only)

Description: Precision Ratioing - Additives (Same as *82 in the WSB)

For Touchscreen Controllers only, may require a firmware update.

Command Format

Field #	Name	Size	Range	Description
1	Address	1	0 to 255	Address of the controller
2	Command Code	1	43	Command
3	Precision On, Precision On, Status	1	0-12, 14	0 = Precision Ratio Off 1 = Precision On for hopper 1 2 = Precision On for hopper 2 3 = Precision On for hopper 3 4 = Precision On for hopper 4 5 = Precision On for hopper 5 6 = Precision On for hopper 6 7 = Precision On for hopper 7 8 = Precision On for hopper 8 9 = Precision On for hopper 9 10 = Precision On for hopper 10 11 = Precision On for hopper 11 12 = Precision On for hopper 12 14 = Get Precision Ratio status
4	Checksum	1	0 to 255	Checksum
Total		4		

Response Format

Field #	Name	Size	Range	Description
1	Address	1	0 to 255	Address of the controller
2	Response Code	1	48	Command
3	ACK/NAK	1	6 or 21	6-ACK, 21=NAK
4	Checksum	1	0 to 255	Checksum
Total		4		

Response Format (subcommand 0:ratio status)

Field #	Name	Size	Range	Description
1	Address	1	0 to 255	Address of the controller
2	Response Code	1	43	Response Code
3	Mode	1	0 - 13	0 = Precision Ratio Off 1 = Precision On for hopper 1 2 = Precision On for hopper 2 3 = Precision On for hopper 3 4 = Precision On for hopper 4 5 = Precision On for hopper 5 6 = Precision On for hopper 6 7 = Precision On for hopper 7 8 = Precision On for hopper 8 9 = Precision On for hopper 9 10 = Precision On for hopper 10 11 = Precision On for hopper 11 12 = Precision On for hopper 12 13 = hopper not enabled
4	Checksum	1	0 to 255	Checksum
Total		4		

Maguire Gravimetric Feeder (MGF) MLAN Commands

The Maguire Gravimetric Feeder uses the following MLAN Protocol commands for data communications. These MLAN commands are available in the latest controller firmware versions. A firmware update may be necessary to include all commands.

MGF MLAN Command Index:

Command	Page
Abort Cycle or Retry	69
Clear Totals	70
Clear Totals Immediately	71
Get Address	72
Get All Parameters	73
Get Shot Weight	74
Get Cycle Weigh and Time	75
Get Cycle Weigh and Time (4 bytes version)	76
Get Display	77
Get Display (Extended)	77
Get Parameter	79
Get Target Rate	80
Get LDR	81
Get Status	82
Get Rate	83
Get Target Throughput / Get Shot Weight and Status	84
Get Totals	85
Get Type	86

Command	Page
Get Version	87
Get Weight Units	88
Send LDR	89
Set Date and Time	90
Set Mixer Motor State	91
Set Parameter	92
Set Pause Cycle Flag	93
Set Remote Keypad	94
Set Tag	95
Set Weight Units	96
Silence Alarm	97
Start / Stop / Status	98
Stop Cycle / Stop Retry	99

Abort Cycle or Retry

Description: Aborts the current cycle or aborts the current cycle retry, then continues on to the next cycle when ready. Invalid for LIW controllers.

Command Format

Field #	Name	Size	Range	Description
1	Address	1	0 to 255	Address of the controller
2	Command Code	1	27	Command
3	Abort Command	1	1 or 2	1 = Abort Cycle, 2 = Abort Retry
4	Checksum	1	0 to 255	Checksum
Total		4		

Response Format

Field #	Name	Size	Range	Description
1	Address	1	0 to 255	Address of the controller
2	Response Code	1	48	Response Code
3	ACK/NAK	1	6 or 21	6-ACK, 21=NAK
	Checksum	1	0 to 255	Checksum
Total		4		

Clear Totals

Description: Resets the totals to zero.

Command Format

Field #	Name	Size	Range	Description
1	Address	1	0 to 255	Address of the controller
2	Command Code	1	24	Command
3	Checksum	1	0 to 255	Checksum
Total		3		

Response Format

Field #	Name	Size	Range	Description
1	Address	1	0 to 255	Address of the controller
2	Response Code	1	48	Response Code
3	ACK/NAK	1	6 or 21	6-ACK, 21=NAK
	Checksum	1	0 to 255	Checksum
Total		4		

Clear Totals Immediately

Description: Resets the totals to zero.

Command Format

Field #	Name	Size	Range	Description
1	Address	1	0 to 255	Address of the controller
2	Command Code	1	24	Command
3	Checksum	1	0 to 255	Checksum
Total		3		

Response Format

Field #	Name	Size	Range	Description
1	Address	1	0 to 255	Address of the controller
2	Response Code	1	48	Response Code
3	ACK/NAK	1	6 or 21	6-ACK, 21=NAK
	Checksum	1	0 to 255	Checksum
Total		4		

Get Address

Description: Returns the address of the controller.

Command Format

Field #	Name	Size	Range	Description
1	Address	1	0 to 255	Address of the controller
2	Command Code	1	54	Command
3	Checksum	1	0 to 255	Checksum
Total		3		

Response Format

Field #	Name	Size	Range	Description
1	Address	1	0 to 255	Address of the controller
2	Response Code	1	54	Response Code
3	Pad	1	0	Padding always zero
4	ID	1	0 - 255	Address / ID of controller
5	Baud Rate	1	1	1=1200 baud
6	Checksum	1	0 to 255	Checksum
Total		6		

Get All Parameters

Description: Returns all of the parameters and their current values.

Command Format

Field #	Name	Size	Range	Description
1	Address	1	0 to 255	Address of the controller
2	Command Code	1	22	Command
3	Sequence #	2	1-65,536	See Appendix B
4	Checksum	1	0 to 255	Checksum
Total		5		

Response Format

Field #	Name	Size	Range	Description
1	Address	1	0 to 255	Address of the controller
2	Response Code	1	22	Response Code
3	Sequence #	2	1-65,536	See Appendix B (page 107)
4	Packet	32	Each byte 0 - 255	See Appendix B (page 107)
5	Checksum	1	0 to 255	Checksum
Total		37		

NOTE: Parameters are given in the MGF manual. A three letter acronym that begins with an underscore (_) should be replaced with a binary # between 1 and 12. This number corresponds to the component #. In the MGF, the only component used is the 12th component.

NOTE: Additional parameters beyond the parameters listed in the MGF manual are returned with this command. Only those that are documented in the MGF manual are applicable to the MGF. The additional parameters are returned only to satisfy some computer programs that need this additional information.

Get Shot Weight

Description: This command only applies to cycle mode and returns the shot weight (SHT parameter) dispensed during cycle mode in whole grams.

Command Format

Field #	Name	Size	Range	Description
1	Address	1	0 to 255	Address of the controller
2	Command Code	1	84	Command
3	Checksum	1	0 to 255	Checksum
Total		3		

Response Format

Field #	Name	Size	Range	Description
1	Address	1	0 to 255	Address of the controller
2	Response Code	1	84	Response Code
3	Shot Weight	4	0-4,294,967,295	Shot weight (grams only) Same as SHT parameter in MGF
4	Pad	4	zeros	Padding of zeros
5	Checksum	1	0 to 255	Checksum
Total		11		

Get Cycle Weight and Time

Description:

In **CYCLE MODE**: Returns the weight dispensed of the last cycle and the duration of time between the last two cycles.

In **CONTINUOUS MODE**: Returns the loss in weight from Fill to Fill and the Fill to Fill time.

Command Format

Field #	Name	Size	Range	Description
1	Address	1	0 to 255	Address of the controller
2	Command Code	1	50	Command
3	Checksum	1	0 to 255	Checksum
Total		3		

Response Format

Field #	Name	Size	Range	Description
1	Address	1	0 to 255	Address of the controller
2	Response Code	1	50	Response Code
3	Cycle Mode: Dispense weight of last cycle Continuous Mode: The loss in weight from fill to fill.	2	0-65,536	Cycle Mode: Dispense weight of last cycle (grams) Continuous Mode: The loss in weight from fill to fill (grams).
4	Cycle Mode: Screw Signal Time of last cycle Continuous Mode: Fill to Fill Time.	4	0-4,294,967,295	Cycle Mode: Number of interrupts during the last cycle (244/sec) Continuous Mode: The time elapsed form Fill to Fill.
5	Checksum	1	0 to 255	Checksum
Total		9		

Get Cycle Weight and Time (4 byte)

Description:

In **CYCLE MODE**: Returns the weight dispensed of the last cycle and the duration of time between the last two cycles.

In **CONTINUOUS MODE**: Returns the loss in weight from Fill to Fill and the Fill to Fill time.

Command Format

Field #	Name	Size	Range	Description
1	Address	1	0 to 255	Address of the controller
2	Command Code	1	79	Command
3	Checksum	1	0 to 255	Checksum
Total		3		

Response Format

Field #	Name	Size	Range	Description
1	Address	1	0 to 255	Address of the controller
2	Response Code	1	79	Response Code
3	Cycle Mode: Dispense weight of last cycle Continuous Mode: The loss in weight from fill to fill.	4	0-4,294,967,295	Cycle Mode: Dispense weight of last cycle (grams) Continuous Mode: The loss in weight from fill to fill (grams).
4	Cycle Mode: Screw Signal Time of last cycle Continuous Mode: Fill to Fill Time.	4	0-4,294,967,295	Cycle Mode: Number of interrupts during the last cycle (244/sec) Continuous Mode: The time elapsed form Fill to Fill.
5	Checksum	1	0 to 255	Checksum
Total		11		

Get Display

Description: Returns the current display buffer.

Command Format

Field #	Name	Size	Range	Description
1	Address	1	0 to 255	Address of the controller
2	Command Code	1	71	Command
3	Checksum	1	0 to 255	Checksum
Total		3		

Response Format

Field #	Name	Size	Range	Description
1	Address	1	0 to 255	Address of the controller
2	Response Code	1	71	Response Code
3	Display	8	ASCII	ASCII character currently on display Most significant byte is the leftmost character. Supports 4 line format of MGF display.
5	Checksum	1	0 to 255	Checksum
Total		11		

Get Display Extended

Description: Returns the current display buffer.

Command Format

Field #	Name	Size	Range	Description
1	Address	1	0 to 255	Address of the controller
2	Command Code	1	112	Command
3	Checksum	1	0 to 255	Checksum
Total		3		

Response Format

Field #	Name	Size	Range	Description
1	Address	1	0 to 255	Address of the controller
2	Response Code	1	112	Response Code
3	Display	40	ASCII	ASCII character currently on display Most significant byte is the leftmost character
5	Checksum	1	0 to 255	Checksum
Total		43		

Get Parameter

Description: Gets a single parameter. Parameters are MGF specific. See Appendix B (page 107) or the MGF Manual for 3 letter parameter acronyms and the parameter description.

Command Format

Field #	Name	Size	Range	Description
1	Address	1	0 to 255	Address of the controller
2	Command Code	1	69	Command
3	Parameter ID	3	ASCII	Three letter acronym designating the parameter.
4	Padding	2	0	Padding always zero
5	Checksum	1	0 to 255	Checksum
Total		8		

Response Format

Field #	Name	Size	Range	Description
1	Address	1	0 to 255	Address of the controller
2	Response Code	1	69	Response Code
3	Parameter Value	2	0-65,536	The value of the parameter.
5	Checksum	1	0 to 255	Checksum
Total		5		

NOTE: Parameters are given in the Product's manual (WSB, LIW, MGF). A three letter acronym that begins with an underscore (_) should be replaced with a binary # between 1 and 12. This number corresponds to the component #.

Get Target Rate

Description: Returns the targeted throughput in grams / hr. (continuous mode only).

Command Format

Field #	Name	Size	Range	Description
1	Address	1	0 to 255	Address of the controller
2	Command Code	1	57	Command
3	Checksum	1	0 to 255	Checksum
		Total	3	

Response Format

Field #	Name	Size	0 to 255	Description
1	Address	1	0 to 255	Address of the controller
2	Response Code	1	57	Response code
3	Targeted Rate	4	0 to 4,294,967,295	Targeted Rate in grams
4	Checksum	1	0 to 255	Checksum
		Total	7	

Get LDR Percentage

Description: Returns the current LDR percentage, recipe #, work order #, and operator #.
Formatted same as the WSB Get Settings.

Command Format (type 1 - Four Component Software)

Field #	Name	Size	Range	Description
1	Address	1	0 to 255	Address of the controller
2	Command Code	1	20	Command
3	Checksum	1	0 to 255	Checksum
Total		3		

Response Format

Field #	Name	Size	Range	Description
1	Address	1	0 to 255	Address of the controller
2	Response Code	1	20	Response Code
3	System Type	1	2 or 3	2=tenths of grams, also, NO change in totals since last get total cmd (16) 3=tenths of grams, also, change in totals since last get total cmd (16)
4	Software Type	1	12	12 = using 12 th component (MGF only)
5	Padding of zeros	33	0	Padding always zero
6	Type Hopper 12	1	2	Always 2
7	Setting Hopper 12	2	0 to 999	LDR Percentage with Implied decimal point #.##
8	Recipe Number	2	100 to 65,536	Recipe Number
9	Operator Number	2	0 to 999	Operator Number
10	Work Order Number	4	0 to 999,999	Work Order Number
11	Checksum	1	0 to 255	Checksum
Total		49		

Get Status

Description: Motor, Loader, Alarm

Command Format

Field #	Name	Size	Range	Description
1	Address	1	0 to 255	Address of the controller
2	Command Code	1	53	Command
3	Checksum	1	0 to 255	Checksum
Total		3		

Response Format

Field #	Name	Size	Range	Description
1	Address	1	0 to 255	Address of the controller
2	Response Code	1	53	Response Code
3	Output Status	2	0 to 65535	See Note 1
4	Alarm Status	1	0 to 255	See Note 2
5	Sensor Status	1	0 to 255	See Note 3
6	Checksum	1	0 to 255	Checksum
Total		7		

Note 1 – Output Status

Bit	Name	Value	Description
0-12	Padding with zeros	0	
13	Motor	1=on 0=off	
14	Padded with zero	0	
15	Alarm	1=on 0=off	See Alarm Status below

Note 2 – Alarm Status

Bit	Name	Value	Description
0-6	Alarm Code	Code = 48: No Metering Code = 49: Loading Too Slowly Code = 50: Prime Function Timed Out Code = 51: Low Weight Code = 52: Over Weight Code = 53: Exceeds Motor Capacity Code = 54: Bin Removed Code = 55: Max Adjustment Rate Code = 56: Min Adjustment Rate Code = 57: LIW Timed Out Code = 58: Loadcell Error	Bit 0 is the rightmost bit
7	Alarm Silenced	1=silenced	Leftmost bit

Note 3 – Sensor Status

Bit	Name	Value	Description
0-1	Reserved	0	Rightmost Bit
2	Silence Alarm Button	1=yes 0=no	
3-5	Reserved	0	
6	Running Mode	1=yes 0=no	
7	Soft Stop Mode	1=yes 0=no	Leftmost bit

Get Rate

Description: Returns the actual dispense weight in grams / hr. while in Continuous Mode.
Returns the averaged dispensed grams since the last adjustment while in Cycle Mode.

Command Format

Field #	Name	Size	Range	Description
1	Address	1	0 to 255	Address of the controller
2	Command Code	1	64	Command
3	Checksum	1	0 to 255	Checksum
Total		3		

Response Format

Field #	Name	Size	Range	Description
1	Address	1	0 to 255	Address of the controller
2	Response Code	1	64	Command
3	Rate	4	0 to 4,294,967,295	Grams per hour in Continuous Mode Averaged dispensed grams in cycle mode
4	Checksum	1	0 to 255	Checksum
Total		7		

Get Target Throughput / Shot Weight

Description: Returns the current, user entered throughput for **CONTINUOUS / EXTRUSION FOLLOWING** mode or returns the current user entered target shot weight for **CYCLE** mode.

Command Format

Field #	Name	Size	Range	Description
1	Address	1	0 to 255	Address of the controller
2	Command Code	1	29	Command
3	Checksum	1	0 to 255	Checksum
Total		3		

Response Format

Field #	Name	Size	Range	Description
1	Address	1	0 to 255	Address of the controller
2	Response Code	1	29	Response code
3	Current Mode	1	0 or 1	0=cycle mode, 1=continuous mode
4	Target Throughput (continuous mode) or, Shot Weight (cycle mode).	4	0 to 4,294,967,295	Target Throughput (when in continuous mode) or, Shot Weight (when in cycle mode).
5	Checksum	1	0 to 255	Checksum
Total		8		

Get Totals

Description: Returns the current accumulated total of MGF.

Command Format

Field #	Name	Size	Range	Description
1	Address	1	0 to 255	Address of the controller
2	Command Code	1	16 or 17	See Note 2
3	Checksum	1	0 to 255	Checksum
Total		3		

Response Format

Field #	Name	Size	Range	Description
1	Address	1	0 to 255	Address of the controller
2	Response Code	1	16 or 17	See Note 2
3	System Type	1	2	2=tenths of grams
4	Software Type	1	12	12 = using 12 th component (MGF only)
5	Sequence Number	2	0	Reserved for future use
6	Cycles	2	0 to 65,536	Number of cycles (Cycle Mode Only)
7	Clear / Turnover Flags	2	0 to 65,536	See Note 1
8	Padding of zeros	44	0	Padding always zero
9	Totals	4	0 to 4,294,967,295	Tenths of Grams
10	Checksum	1	0 to 255	Checksum
Total		59		

Note 1 - Flag

Bit	Name	Description	
0	Turnover flag	1=on 2 =off	Address of the controller
1-11	Padding of zeros	0	Always 0
12	Total	1=on 2 =off	1 = total for component turned over
13	Total and Cycle	1=on 2 =off	1 = total, cycle count cleared

Note 2: If the "Command Code" is set to 16, the controller will reset an internal flag indicating that the totals have been received. If, however, "Command Code" is set to 17, the flag will NOT be reset. See the "System Type" part of the "Get Settings" command for how the internal flag is used.

Get Type

Description: Returns the system type of MGF controller, tenths of grams or whole grams.

Command Format

Field #	Name	Size	Range	Description
1	Address	1	0 to 255	Address of the controller
2	Command Code	1	49	Command
3	Checksum	1	0 to 255	Checksum
Total		3		

Response Format

Field #	Name	Size	Range	Description
1	Address	1	0 to 255	Address of the controller
2	Response Code	1	49	Response Code
3	System Type	1	2 or 9	2=tenths of grams, 9=grams
4	Software Type	1	12	Always 12
5	Checksum	1	0 to 255	Checksum
Total		5		

Get Version

Description: Returns the version of the software in the controller.

Command Format

Field #	Name	Size	Range	Description
1	Address	1	0 to 255	Address of the controller
2	Command Code	1	80	Command
3	Checksum	1	0 to 255	Checksum
Total		3		

Response Format

Field #	Name	Size	Range	Description
1	Address	1	0 to 255	Address of the controller
2	Response Code	1	80	Response Code
3	Version Number	6	ASCII	Software Version Number (ASCII)
4	Checksum	1	0 to 255	Checksum
Total		9		

Get Weight Units

Description: Returns the units that the controller is using to display totals, pounds, grams or kilograms.

Command Format

Field #	Name	Size	Range	Description
1	Address	1	0 to 255	Address of the controller
2	Command Code	1	85	Command
3	Checksum	1	0 to 255	Checksum
Total		3		

Response Format

Field #	Name	Size	Range	Description
1	Address	1	0 to 255	Address of the controller
2	Response Code	1	85	Response Code
3	Weight Units	1	0 or 4	0=pounds, 2=grams (cycle mode only), 4=kilograms
4	Checksum	1	0 to 255	Checksum
Total		4		

Send LDR Setting

Description: current LDR percentage, recipe #, work order #, and operator #.
Formatted same as the WSB Send Settings.

Command Format

Field #	Name	Size	Range	Description
1	Address	1	0 to 255	Address of the controller
2	Command Code	1	19	Command Code
3	Padding of zeros	34	0	Padding always zero
4	LDR Setting	2	0 to 999	LDR Percentage with Implied decimal point #.##
5	Recipe Number	2	100 to 65,536	Recipe Number
6	Work Order Number	3	0 to 999,999	Work Order Number
7	Operator Number	2	0 to 999	Operator Number
8	Checksum	1	0 to 255	Checksum
Total		46		

Response Format

Field #	Name	Size	Range	Description
1	Address	1	0 to 255	Address of the controller
2	Response Code	1	19	Response Code
3	ACK/NAK	1	6 or 21	6-ACK, 21=NAK
4	Checksum	1	0 to 255	Checksum
Total		4		

Set Date and Time

Description: Sets the date and time for a particular controller. If the address used is 0, all Maguire controllers are set with the new date and time and NO response is sent back.

Command Format

Field #	Name	Size	Range	Description
1	Address	1	0 to 255	Address of the controller
2	Command Code	1	81	Command
3	Date and Time	8	See Note 1	See Note 1
3	Checksum	1	0 to 255	Checksum
Total		11		

Note 1 – Date and Time

Bit #	Name	Range	Description
0 to 7	Padding	0	
8 to 11	Seconds (ones place)	0 to 9	yy/mm/dd hh:mm:sS
12 to 14	Seconds (tens place)	0 to 5	yy/mm/dd hh:mm:Ss
15	Padding	0	
16 to 19	Minutes (ones place)	0 to 9	yy/mm/dd hh:mM:ss
20 to 22	Minutes (tens place)	0 to 5	yy/mm/dd hh:Mm:ss
23	Padding	0	
24 to 27	Hours (ones place)	0 to 9	yy/mm/dd hH:mm:ss
28 to 29	Hours (tens place)	0 to 2	yy/mm/dd Hh:mm:ss
30	Padding	0	
31	One	1	
32 to 34	Day of week	1 to 7	1 = sunday, 2=monday, ..., 7=saturday
35	Padding	0	
36	One	1	
37	Padding	0	
38 to 39	Padding	0	
40 to 43	Day (ones place)	0 to 9	yy/mm/dDhh:mm:ss
44 to 45	Day (tens place)	0 to 3	yy/mm/Dd hh:mm:ss
46 to 47	Padding	0	
48 to 51	Month (ones place)	0 to 9	yy/mM/dd hh:mm:ss
52	Month (tens place)	0 or 1	yy/Mm/dd hh:mm:ss
53 to 55	Padding	0	
56 to 59	Year (ones place)	0 to 9	yY/mm/dd hh:mm:ss
60 to 63	Years (tens place)	0 to 9	Yy/mm/dd hh:mm:ss

Response Format

Field #	Name	Size	Range	Description
1	Address	1	0 to 255	Address of the controller
2	Response Code	1	48	Response Code
3	ACK/NAK	1	6 or 21	6-ACK, 21=NAK
4	Checksum	1	0 to 255	Checksum
Total		4		

Set Motor State

Description: Sets the State of the motor. Useful for priming remotely.

Command Format

Field #	Name	Size	Range	Description
1	Address	1	0 to 255	Address of the controller
2	Command Code	1	66	Command
3	Motor State	3	0 or 1	0 = Motor OFF, 1 = Motor On
3	Checksum	1	0 to 255	Checksum
Total		3		

Response Format

Field #	Name	Size	Range	Description
1	Address	1	0 to 255	Address of the controller
2	Response Code	1	48	Response Code
3	ACK/NAK	1	6 or 21	6-ACK, 21=NAK
4	Checksum	1	0 to 255	Checksum
Total		4		

Set Parameter

Description: Sets a single parameter

Command Format

Field #	Name	Size	Range	Description
1	Address	1	0 to 255	Address of the controller
2	Command Code	1	68	Command
3	Parameter ID	3	ASCII	Three letter acronym designating parameter.
4	Parameter Value	2	0 to 65,536	The value of the parameter
5	Checksum	1	0 to 255	Checksum
Total		8		

Response Format

Field #	Name	Size	Range	Description
1	Address	1	0 to 255	Address of the controller
2	Response Code	1	48	Response Code
3	ACK/NAK	1	6 or 21	6-ACK, 21=NAK
4	Checksum	1	0 to 255	Checksum
Total		4		

Note: Parameters are given in the MGF manual.

Set Pause Flag

Description: Pauses the MGF Immediately.

Command Format

Field #	Name	Size	Range	Description
1	Address	1	0 to 255	Address of the controller
2	Command Code	1	25	Command
3	Pause Flag	1	0 or 1	0 = OFF (not paused), 1 = ON (paused)
4	Checksum	1	0 to 255	Checksum
Total		4		

Response Format

Field #	Name	Size	Range	Description
1	Address	1	0 to 255	Address of the controller
2	Response Code	1	48	Response Code
3	ACK/NAK	1	6 or 21	6-ACK, 21=NAK
4	Checksum	1	0 to 255	Checksum
Total		4		

Note: This command does the same as using the RUN / STOP toggle on the controller. When this MLAN command is used to pause the MGF immediately, the STOP toggle on the controller will still function to stop the MGF immediately. If both are set, both will cause the MGF to remain stopped until both are set to continue.

Set Remote Keypad

Description: Enables or disables the controller's keypad and / or the "Send Keystroke" MLAN command.

Command Format

Field #	Name	Size	Range	Description
1	Address	1	0 to 255	Address of the controller
2	Command Code	1	88	Command
3	FLAG	1	0 or 1	See Note 1
4	Checksum	1	0 to 255	Checksum
Total		4		

Response Format

Field #	Name	Size	Range	Description
1	Address	1	0 to 255	Address of the controller
2	Response Code	1	48	Response Code
3	ACK/NAK	1	6 or 21	6-ACK, 21=NAK
4	Checksum	1	0 to 255	Checksum
Total		4		

Note 1: A flag of 0 enables the keypad on the controller and disables the "Send Keystroke" MLAN command. A flag of 1 disables the keypad and enables the command.

Set Tag

Description: Sets a single tag value, either recipe #, work order #, or operator #.

Command Format

Field #	Name	Size	Range	Description
1	Address	1	0 to 255	Address of the controller
2	Command Code	1	90	Command
3	Tag ID	2	ASCII	Two letter acronym designating tag.
4	Tag Value	4	0 to 4,294,967,295	The value of the tag. Recipe numbers: 0 to 65,536 Work order numbers: 0 to 999,999 Operator numbers: 0 to 999
3	Checksum	1	0 to 255	Checksum
Total		3		

Response Format

Field #	Name	Size	Range	Description
1	Address	1	0 to 255	Address of the controller
2	Response Code	1	48	Response Code
3	ACK/NAK	1	6 or 21	6-ACK, 21=NAK
4	Checksum	1	0 to 255	Checksum
Total		4		

Set Weight Units

Description: Sets the units that the controller uses to display totals, pounds, grams or kilograms.

Command Format

Field #	Name	Size	Range	Description
1	Address	1	0 to 255	Address of the controller
2	Command Code	1	86	Command
3	Weight Units	1	0 or 4	0 = Pounds, 2=gram (cycle mode only), 4 = Kilograms
4	Checksum	1	0 to 255	Checksum
Total		4		

Response Format

Field #	Name	Size	Range	Description
1	Address	1	0 to 255	Address of the controller
2	Response Code	1	48	Response Code
3	ACK/NAK	1	6 or 21	6-ACK, 21=NAK
4	Checksum	1	0 to 255	Checksum
Total		4		

Silence Alarm

Description: Has the same effect as if the alarm was silenced on the controller.

Command Format

Field #	Name	Size	Range	Description
1	Address	1	0 to 255	Address of the controller
2	Command Code	1	82	Command
3	Checksum	1	0 to 255	Checksum
Total		3		

Response Format

Field #	Name	Size	Range	Description
1	Address	1	0 to 255	Address of the controller
2	Response Code	1	48	Response Code
3	ACK/NAK	1	6 or 21	6-ACK, 21=NAK
4	Checksum	1	0 to 255	Checksum
Total		4		

Start/Stop/Status

Description: Either causes the MGF to stop (at the end of the current cycle in cycle mode), start up again, or return its current status.

Command Format

Field #	Name	Size	Range	Description
1	Address	1	0 to 255	Address of the controller
2	Command Code	1	55	Command
3	Subcommand	1	0, 1, or 2	0=mode status, 1=soft stop, 2=soft start
3	Checksum	1	0 to 255	Checksum
Total		3		

Response Format

Field #	Name	Size	Range	Description
1	Address	1	0 to 255	Address of the controller
2	Response Code	1	48	Response Code
3	ACK/NAK	1	6 or 21	6-ACK, 21=NAK
	Checksum	1	0 to 255	Checksum
Total		4		

Response Format (Subcommand 0:mode status)

Field #	Name	Size	Range	Description
1	Address	1	0 to 255	Address of the controller
2	Response Code	1	55	Response Code
3	Mode	1	0, 1, or 2	0=hard stop 1=soft stop 2=automatic mode/running mode
	Checksum	1	0 to 255	Checksum
Total		4		

Stop Cycle / Stop Retry

Description: Causes the MGF to abort the current cycle (in cycle mode). Aborting the current cycle (in cycle mode) causes the MGF to start the next cycle. Stop retry causes the MGF to stop this cycle and not start the next cycle.

Command Format

Field #	Name	Size	Range	Description
1	Address	1	0 to 255	Address of the controller
2	Command Code	1	27	Command
3	Subcommand	1	1, or 2	1 = Stop Cycle; 2 = Stop Retry
3	Checksum	1	0 to 255	Checksum
Total		3		

Response Format

Field #	Name	Size	Range	Description
1	Address	1	0 to 255	Address of the controller
2	Response Code	1	48	Response Code
3	ACK/NAK	1	6 or 21	6-ACK, 21=NAK
	Checksum	1	0 to 255	Checksum
Total		4		

Maguire Low Pressure Dryer (LPD) MLAN Commands

The Maguire LPD uses the following MLAN Protocol commands for data communications. These MLAN commands are available in the latest controller firmware versions. A firmware update may be necessary to include all commands.

LPD MLAN Command Index:

Command	Page
Set Parameter	101
Get Parameter	102
Get Status	103
Get Version	104
Get Alarm Log Record	105
Get Display	106

Set Parameter (LPD)

Description: Sets a single parameter in the LPD Dryer.

Command Format

Field #	Name	Size	Range	Description
1	Address	1	0 to 255	Address of the controller
2	Command Code	1	68	Command
3	Parameter ID	3	ASCII	Three (3) letter parameter designator
4	Parameter Value	2	0 to 65535	The new parameter value
5	Checksum	1	0 to 255	Checksum
Total		8		

Response Format

Field #	Name	Size	Range	Description
1	Address	1	0 to 255	Address of the controller
2	Response Code	1	48	Response Code
3	ACK/NAK	1	6 or 21	6-ACK, 21=NAK
	Checksum	1	0 to 255	Checksum
Total		4		

NOTE: Parameters are given in the LPD manual.

Get Parameter (LPD)

Description: Gets a single parameter from the LPD Dryer.

Command Format

Field #	Name	Size	Range	Description
1	Address	1	0 to 255	Address of the controller
2	Command Code	1	69	Command
3	Parameter ID	3	ASCII	Three letter acronym designating parameter.
4	Padding	2	0	Padding always zero
5	Checksum	1	0 to 255	Checksum
Total		8		

Response Format

Field #	Name	Size	Range	Description
1	Address	1	0 to 255	Address of the controller
2	Response Code	1	69	Response code
3	Parameter Value	2	0-65,536	The value of the parameter.
4	Checksum	1	0 to 255	Checksum
Total		5		

NOTE: Parameters are given in the LPD manual.

Get Status (LPD)

Description: Returns the current state of all signal inputs and outputs. See LPD manual for more information.

Command Format

Field #	Name	Size	Range	Description
1	Address	1	0 to 255	Address of the controller
2	Command Code	1	74	Command
3	Checksum	1	0 to 255	Checksum
		Total	3	

Response Format

Field #	Name	Size	Range	Description
1	Address	1	0 to 255	Address of the controller
2	Response Code	1	74	Response code
3	Temperature	2	0 to 65535	Temperature in 0.1 degrees C
4	Vacuum	2	0 to 65535	Vacuum in 0.1 mm Hg
5	Flags	2		System Flags bit 0: 1=running cycle; 0=stopped bit 1: 1=heat on; 0=heat off bit 2: 1=vacuum on; 0=vacuum off bit 3: 1= 2 nd vacuum on; 0=2 nd vacuum off bit 4 to bit 15: Reserved for future expansion
6	Cycle Time	2	0 to 65535	Elapsed cycle time in seconds
7	Heat %	2	0 to 65535	Current heat % (-1 when turned off)
8	Alarm Code	1	0 to 255	1 = Cycle time error (takeoff tray empty) 2 = Material convey error 3 = No heat 4 = Vacuum failure 5 = Fail safe alarm 6 = Target temp too high 8 = Canisters did not index 9 = Canister not found 10 = Canisters did not lock 11 = Bad temperature sensor data 12 = No Heat Rise 13 = Temperature above set point 14 = No target temperature set 15 = Cycle time not set 17 = Maximum Clean Time exceeded 18 = Fill Time exceeded 19 = Material Ready (informational) 20 = Index Complete (informational) 21 = Hopper Empty
9	Checksum	1	0 to 255	Checksum
		Total	14	

Get Version

Description: Returns the version of the software in the LPD controller.

Command Format

Field #	Name	Size	Range	Description
1	Address	1	0 to 255	Address of the controller
2	Command Code	1	80	Command
3	Checksum	1	0 to 255	Checksum
Total		3		

Response Format

Field #	Name	Size	Range	Description
1	Address	1	0 to 255	Address of the controller
2	Response Code	1	80	Response code
3	Version Number	6	ASCII	Software version number (ASCII)
4	Checksum	1	0 to 255	Checksum
Total		9		

Get Alarm Log Record (LPD)

Description: Returns alarm log records.

Command Format

Field #	Name	Size	Range	Description
1	Address	1	0 to 255	Address of the controller
2	Command Code	1	96	Command
3	Record Number	1	0 - 24	Requested record number
3	Checksum	1	0 to 255	Checksum
		Total	4	

Response Format with records available

Field #	Name	Size	Range	Description
1	Address	1	0 to 255	Address of the controller
2	Response Code	1	96	Response code
3	Record Number	1	0 to 24	Record number
4	Seconds	1	0 to 59	Time stamp: seconds
5	Minutes	1	0 to 59	Time stamp: minutes
6	Hour	1	0 to 23	Time stamp: 24 hour format)
7	Day of Week	1	0 to 6	Time stamp: day of week (0=Sunday)
8	Date	1	1 to 31	Time stamp: date
9	Month	1	1 to 12	Time stamp: month
10	Year	1	0 to 65535	Time stamp: year
11	Alarm Code	1	0 to 255	Alarm code
12	Padding	6	0	Reserved for future expansion
13	Checksum	1	0 to 255	Checksum
		Total	14	

Response Format when records not found

Field #	Name	Size	Range	Description
1	Address	1	0 to 255	Address of the controller
2	Response Code	1	48	Response code
3	NAK	1	21	21=NAK
4	Checksum	1	0 to 255	Checksum
		Total	4	

Get Display (LPD)

Description: Returns the current display buffer. This command returns LPD controller's 40-character display.

Command Format

Field #	Name	Size	Range	Description
1	Address	1	0 to 255	Address of the controller
2	Command Code	1	112	Command
3	Checksum	1	0 to 255	Checksum
Total		3		

Response Format

Field #	Name	Size	Range	Description
1	Address	1	0 to 255	Address of the controller
2	Response Code	1	112	Response Code
3	Display	40	ASCII	ASCII character currently on display Most significant byte is the leftmost character
5	Checksum	1	0 to 255	Checksum
Total		43		

Appendix B – Get All Parameters

The “Get All Parameters” command is complicated relative to all of the other MLAN commands. The purpose of this appendix is to explain the details of the command.

The “Get All Parameters” command returns packets. Each packet is 32 bytes in length, excluding the first packet, which is 30 bytes. The user should treat all packets as one long stream of data. The first time the command is sent to a blender, the response contains two bytes, which indicate the number of packets to follow. The initial response also contains the first packet, which is only 30 bytes in length. Each subsequent packet is retrieved by sending the command to the controller with the next packet number.

After all packets have been received, the stream can then be broken down into the appropriate parameter table. The stream of data will consist of all the parameter names (3 byte chunks) followed by the corresponding parameter values (2 byte chunks). The end of the parameter names will be indicated by the special “END” parameter.

EXAMPLE (WSB four component software): The table on page 108 is a byte by byte recording of a transmission between a PC and a Maguire Weigh Scale Blender (WSB). The WSB’s ID number is set to 1. The first two bytes of every transmission consist of the WSB ID number (001) and the command number (022). The last byte of every transmission is the checksum for the transmission. Each byte is represented as a three-digit ASCII number. The parameter table which this transmission represents is given on page 109. Note: the first 3 bytes of packet #1 are 070, 076, and 071. These three bytes represent the “FLG” parameter (ASCII value for: F=070; L=076; G=071), see the table on page 109. The following 3 bytes, 082, 065, and 076 represent the “RAL” parameter. The parameter names continue until the “END” parameter is reached. This occurs in the 7th packet. Look for the byte sequence 069, 078, and 068 (they are shown in bold print). The parameter values begin immediately following the “END” parameter. The value of the first parameter is 0, given by the two bytes 000 and 000. The value of the 6th parameter is 3010, given by the two bytes 011 and 194 ($11*256+194=3010$).

Twelve component software is more complex. All of the parameters in twelve software that relate directly to a particular component are transmitted with one name and twelve values. This is done to save time and space during the transmission. The standard parameters are transmitted first, followed by the component specific parameters. The parameter names still precede the parameter values, with the special “END” parameter separating the two sets. However, another special parameter of three consecutive spaces is used to separate the standard parameters from the component specific ones. The important thing to realize is that the component specific parameter names are transmitted only for component one. They are NOT transmitted for components two through twelve. The only difference in the name is the first character. Component one begins with a “1”, two with a “2”, ..., nine with a “9”, ten with an “A”, eleven with a “B”, and twelve with a “C”. (See the parameter table on page **Error! Bookmark not defined.**)

EXAMPLE (twelve component software): The table on page **Error! Bookmark not defined.** is a byte by byte recording of a transmission between a PC and a Maguire Weigh Scale Blender (WSB). The WSB’s ID number is set to 3. The first two bytes of every transmission consist of the WSB ID number (003) and the command number (022). The last byte of every transmission is the checksum for the transmission. Each byte is represented as a three-digit ASCII number. The parameter table which this transmission represents is given on page **Error! Bookmark not defined.** Note: the first 3 bytes of packet #1 are 070, 076, and 071. These three bytes represent the “FLG” parameter (ASCII value for: F=070; L=076; G=071), see the table on page **Error! Bookmark not defined.** The following 3 bytes, 077, 073, and 088 represent the “MIX” parameter. The standard parameter names continue until the special parameter of three spaces is reached. This occurs in the 3rd packet. Look for the byte sequence 032, 032, and 032 (they are shown in bold print). The component specific parameters follow. They all begin with a space (032), which in the parameter table on page **Error! Bookmark not defined.**, is replaced with the component number. The parameter names continue until the “END” parameter is reached. This occurs in the 4th packet. Look for the byte sequence 069, 078, and 068 (they are shown in bold print). The parameter values begin immediately following the “END” parameter. The value of the first parameter is 0, given by the two bytes 000 and 000. The value of the 2nd parameter is 3010, given by the two bytes 011 and 194 ($11*256+194=3010$).

Sample Transmission of "Get All Parameters," with a Four-Component WSB

	Address	Cmd	Seq #	# of Packets	Packet	Checksum
Initial Command (PC to WSB)	001	022	000 001			231
First Response (WSB to PC)	001	022	000 001	000 011	070 076 071 082 065 076 078 065 076 067 065 076 065 065 076 077 073 088 070 067 086 068 084 073 075 068 070 087 068 070	071
Request for Seq #2 (PC to WSB)	001	022	000 002			230
Response for Seq #2 (WSB to PC)	001	022	000 002		066 069 082 067 088 084 065 088 084 082 079 067 082 079 086 082 072 076 070 085 076 077 065 088 084 072 032 084 076 032 080 082	133
Request for Seq #3 (PC to WSB)	001	022	000 003			229
Response for Seq #3 (WSB to PC)	001	022	000 003		084 082 083 069 067 083 069 065 083 069 082 076 079 068 076 089 076 084 049 076 084 050 082 080 084 078 080 084 067 080 084 065	106
Request for Seq #4 (PC to WSB)	001	022	000 004			228
Response for Seq #4 (WSB to PC)	001	022	000 004		080 084 082 087 084 082 084 073 078 087 084 078 084 073 067 087 084 067 084 073 065 087 084 065 084 073 082 077 073 078 077 073	012
Request for Seq #5 (PC to WSB)	001	022	000 005			227
Response for Seq #5 (WSB to PC)	001	022	000 005		067 077 073 065 077 073 082 078 067 078 078 067 067 078 067 065 078 067 082 082 080 078 082 080 067 082 080 065 082 080 082 082	123
Request for Seq #6 (PC to WSB)	001	022	000 006			226
Response for Seq #6 (WSB to PC)	001	022	000 006		068 078 082 068 067 082 068 065 082 068 082 076 065 078 076 065 067 076 065 065 076 065 080 082 067 083 084 076 076 067 076 076	179
Request for Seq #7 (PC to WSB)	001	022	000 007			225
Response for Seq #7 (WSB to PC)	001	022	000 007		067 072 076 067 070 076 067 090 088 084 080 069 078 068 000 000 000 000 000 004 000 004 000 004 011 194 000 005 000 010 000 002	219
Request for Seq #8 (PC to WSB)	001	022	000 008			224
Response for Seq #8 (WSB to PC)	001	022	000 008		000 002 000 200 000 000 000 000 000 000 000 000 000 000 015 160 023 112 000 200 000 100 000 000 003 232 003 232 003 232 000 050	193
Request for Seq #9 (PC to WSB)	001	022	000 009			223
Response for Seq #9 (WSB to PC)	001	022	000 009		001 232 000 000 000 000 000 000 000 000 000 000 000 000 081 064 030 128 081 064 030 128 004 000 122 000 004 000 122 000 001 069	086
Request for Seq #10 (PC to WSB)	001	022	000 010			222
Response for Seq #10 (WSB to PC)	001	022	000 010		001 069 000 004 000 001 000 001 000 001 000 001 000 001 000 010 000 010 000 010 000 010 000 081 000 081 000 002 000 005 000 020	170
Request for Seq #11 (PC to WSB)	001	022	000 011			221
Response for Seq #11 (WSB to PC)	001	022	000 011		000 020 000 015 000 015 000 010 000 244 000 080 000 120 000 079 002 071 078 042 000 000 000 000 000 000 000 000 000 000 000 000	213

Sample Parameter Table from Four Component WSB

Name	Value	Name	Value
FLG	0	NWT	20800
RAL	0	NTI	7808
NAL	4	CWT	1024
CAL	4	CTI	31232
AAL	4	AWT	1024
MIX	3010	ATI	31232
FCV	5	RMI	325
DTI	10	NMI	325
KDF	2	CMI	4
WDF	2	AMI	1
BER	200	RNC	1
CXT	0	NNC	1
AXT	0	CNC	1
ROC	0	ANC	1
ROV	0	RRP	10
RHL	0	NRP	10
FUL	4000	CRP	10
MAX	6000	ARP	10
TH	200	RRD	81
TL	100	NRD	81
PRT	0	CRD	2
RSE	1000	ARD	5
CSE	1000	RLA	20
ASE	1000	NLA	20
RLO	50	CLA	15
DLY	488	ALA	15
LT1	0	PRC	10
LT2	0	STL	244
RPT	0	LCL	80
NPT	0	LCH	120
CPT	0	LCF	79
APT	0	LCZ	583
RWT	20800	XTP	20010
RTI	7808		

Sample Transmission of “Get All Parameters,” with a Twelve-Component WSB

	Address	Cmd	Seq #	# of Packets	Packet	Checksum
Initial Command (PC to WSB)	003	022	000 001			229
First Response (WSB to PC)	003	022	000 001	000 016	070 076 071 077 073 088 070 067 086 068 084 073 075 068 070 087 068 070 066 069 082 082 079 067 070 085 076 077 065 088	014
Request for Seq #2 (PC to WSB)	003	022	000 002			228
Response for Seq #2 (WSB to PC)	003	022	000 002		032 084 072 032 084 076 080 082 084 068 076 089 080 082 067 083 084 076 076 067 076 076 067 072 076 067 070 076 067 090 082 079	160
Request for Seq #3 (PC to WSB)	003	022	000 003			227
Response for Seq #3 (WSB to PC)	003	022	000 003		086 082 072 076 088 084 080 068 083 049 068 083 050 032 032 032 032 084 089 032 067 083 032 065 076 032 088 084 032 083 069 032	230
Request for Seq #4 (PC to WSB)	003	022	000 004			226
Response for Seq #4 (WSB to PC)	003	022	000 004		087 084 032 084 073 032 077 073 032 078 067 032 080 084 032 082 080 032 082 068 032 076 065 069 078 068 000 000 011 194 000 006	128
Request for Seq #5 (PC to WSB)	003	022	000 005			225
Response for Seq #5 (WSB to PC)	003	022	000 005		000 010 000 002 000 002 000 200 000 000 015 160 023 112 000 200 000 100 000 000 001 232 000 010 000 244 000 080 000 120 000 079	171
Request for Seq #6 (PC to WSB)	003	022	000 006			224
Response for Seq #6 (WSB to PC)	003	022	000 006		002 071 000 000 000 000 078 042 000 000 000 000 001 000 200 000 004 000 000 003 232 081 064 030 128 001 069 000 001 000 000	241
Request for Seq #7 (PC to WSB)	003	022	000 007			223
Response for Seq #7 (WSB to PC)	003	022	000 007		000 010 000 081 000 020 000 002 000 001 000 004 000 000 003 232 081 064 030 128 001 069 000 001 000 000 000 010 000 100 000 020	134
Request for Seq #8 (PC to WSB)	003	022	000 008			222
Response for Seq #8 (WSB to PC)	003	022	000 008		000 003 000 030 000 004 000 000 003 232 081 064 030 128 001 069 000 001 000 000 000 010 000 100 000 020 000 003 000 020 000 004	187
Request for Seq #9 (PC to WSB)	003	022	000 009			221
Response for Seq #9 (WSB to PC)	003	022	000 009		000 000 003 232 081 064 030 128 001 069 000 001 000 000 000 010 000 100 000 020 000 000 000 000 004 000 000 003 232 004 000	007
Request for Seq #10 (PC to WSB)	003	022	000 010			220
Response for Seq #10 (WSB to PC)	003	022	000 010		122 000 000 001 000 001 000 000 000 010 000 005 000 015 000 000 000 000 000 004 000 000 003 232 004 000 122 000 000 001 000 001	211
Request for Seq #11 (PC to WSB)	003	022	000 011			219
Response for Seq #11 (WSB to PC)	003	022	000 011		000 000 000 010 000 005 000 015 000 000 000 000 000 004 000 000 003 232 081 064 030 128 000 001 000 001 000 000 000 010 000 100	047
Request for Seq #12 (PC to WSB)	003	022	000 012			218
Response for Seq #12 (WSB to PC)	003	022	000 012		000 020 000 000 000 000 000 004 000 000 003 232 081 064 030 128 000 001 000 001 000 000 000 010 000 100 000 020 000 000 000 000	036
Request for Seq #13 (PC to WSB)	003	022	000 013			217
Response for Seq #13 (WSB to PC)	003	022	000 013		000 004 000 000 003 232 004 000 122 000 000 001 000 001 000 000 000 010 000 100 000 015 000 000 000 000 000 004 000 000 003 232	254
Request for Seq #14 (PC to WSB)	003	022	000 014			216
Response for Seq #14 (WSB to PC)	003	022	000 014		004 000 122 000 000 001 000 001 000 000 000 010 000 100 000 015 000 000 000 000 000 004 000 000 003 232 004 000 122 000 000 001	109
Request for Seq #15 (PC to WSB)	003	022	000 015			215
Response for Seq #15 (WSB to PC)	003	022	000 015		000 001 000 000 000 010 000 100 000 015 000 000 000 000 000 004 000 000 003 232 004 000 122 000 000 001 000 001 000 000 000 010	224
Request for Seq #16 (PC to WSB)	003	022	000 016			214
Response for Seq #16 (WSB to PC)	003	022	000 016		000 100 000 015 000	099

Sample Parameter Table from WSB Twelve Component (as of version 01003T)

Prior chip versions may not contain all listed parameters, future chip versions may contain additional parameters.

Name	Value	Name	Value	Name	Value	Name	Value
FLG	00000	2TY	00002	5PT	00000	9SE	01000
MIX	03010	2CS	00000	5RP	00010	9WT	26000
FCV	00006	2AL	00004	5RD	00500	9TI	00976
DTI	00006	2XT	00000	5LA	00020	9MI	00001
KDF	00010	2SE	01000	5PO	00000	9NC	00010
WDF	00010	2WT	26000	6TY	00002	9PT	00000
BER	01000	2TI	00976	6CS	00000	9RP	00010
ROC	00000	2MI	00001	6AL	00004	9RD	00500
ROV	00000	2NC	00010	6XT	00000	9LA	00020
RHL	00000	2PT	00000	6SE	01000	9PO	00000
FUL	20000	2RP	00010	6WT	26000	ATY	00002
MAX	30000	2RD	00500	6TI	00976	ACS	00000
TH	01000	2LA	00020	6MI	00001	AAL	00004
TL	00500	2PO	00000	6NC	00010	AXT	00000
PRT	00000	3TY	00002	6PT	00000	ASE	01000
DLY	00488	3CS	00000	6RP	00010	AWT	26000
PRC	00010	3AL	00004	6RD	00500	ATI	00976
STL	00122	3XT	00000	6LA	00020	AMI	00001
LCL	00027	3SE	01000	6PO	00000	ANC	00010
LCH	00039	3WT	26000	7TY	00002	APT	00000
LCF	00079	3TI	00976	7CS	00000	ARP	00010
LCZ	00583	3MI	00001	7AL	00004	ARD	00500
DS1	00000	3NC	00010	7XT	00000	ALA	00020
DS2	00000	3PT	00000	7SE	01000	APO	00000
XCV	00000	3RP	00010	7WT	26000	BTY	00002
XRC	00001	3RD	00500	7TI	00976	BCS	00000
TCV	00000	3LA	00020	7MI	00001	BAL	00004
TRC	00004	3PO	00000	7NC	00010	BXT	00000
XTP	05050	4TY	00002	7PT	00000	BSE	01000
MPO	00183	4CS	00000	7RP	00010	BWT	26000
SCR	00000	4AL	00004	7RD	00500	BTI	00976
XAL	00005	4XT	00000	7LA	00020	BMI	00001
XUL	00200	4SE	01000	7PO	00000	BNC	00010
BCR	00000	4WT	26000	8TY	00002	BPT	00000
CPL	00000	4TI	00976	8CS	00000	BRP	00010
PTD	00020	4MI	00001	8AL	00004	BRD	00500
MCT	00000	4NC	00010	8XT	00000	BLA	00020
1TY	00002	4PT	00000	8SE	01000	BPO	00000
1CS	00000	4RP	00010	8WT	26000	CTY	00002
1AL	00004	4RD	00500	8TI	00976	CCS	00000
1XT	00000	4LA	00020	8MI	00001	CAL	00004
1SE	01000	4PO	00000	8NC	00010	CXT	00000
1WT	26000	5TY	00002	8PT	00000	CSE	01000
1TI	00976	5CS	00000	8RP	00010	CWT	26000
1MI	00001	5AL	00004	8RD	00500	CTI	00976
1NC	00010	5XT	00000	8LA	00020	CMI	00001
1PT	00000	5SE	01000	8PO	00000	CNC	00010
1RP	00010	5WT	26000	9TY	00002	CPT	00000
1RD	00500	5TI	00976	9CS	00000	CRP	00010
1LA	00020	5MI	00001	9AL	00004	CRD	00500
1PO	00000	5NC	00010	9XT	00000	CLA	00020
						CPO	00000

Acknowledgement of mislabeling in descriptions of Get Settings and Send Settings

Corrections were made to typos in versions of the MLAN protocol manual prior to 4/23/24 in the description of the hopper number in hoppers 3 and 4 under MLAN commands Send Settings and Get Settings for Four Component Software only. The following corrections to the manual do not apply to Twelve Component Software.

Get Settings, Response Format Type 1 - Four Component Software:

Fields 8 & 9 were named Hopper 3 with the description "color" however fields 8 & 9 should have been labeled Hopper 4 with the description "color". This correction to the manual is because the bytes in fields 8 and 9 are the response of the settings of hopper 4, labeled color in the controller.

Also fields 10 & 11 were named Hopper 4 with the description "additive" but they should have been labeled Hopper 3 with the description "additive" This correction to the manual is because the bytes in fields 10 and 11 are the response of the setting of hopper 3, labeled additive in the controller.

Send Settings, Command Format Type 1 - Four Component Software:

Fields 7 & 8 were named Hopper 3 with the description "color" however fields 7 & 8 should have been labeled Hopper 4 with the description "color". This correction to the manual is because the bytes in fields 7 and 8 control the settings of hopper 4, labeled color in the controller.

Also fields 9 & 10 were named Hopper 4 with the description "additive" but they should have been labeled Hopper 3 with the description "additive" This correction to the manual is because the bytes in fields 9 and 10 control hopper 3, labeled additive in the controller. The screenshot below is correct.

Technical Support and Contact Information

Maguire Products Inc.

11 Crozerville Road

Aston, PA 19014

Tel: 610.459.4300

Fax: 610.459.2700

Email: info@maguire.com

Web: www.maguire.com

Maguire Europe

Tame Park

Tamworth

Staffordshire

B775DY

UK

Tel: + 44 1827 265 850

Fax: + 44 1827 265 855

Email: info@maguire-europe.com

Maguire Products Asia PTE LTD

Main Office

15 Changi North Street 1

#01-15, I-Lofts

Singapore 498765

Tel: 65 6848-7117

Fax: 65 6542-8577

E-mail: magasia@maguire-products.com.sg