

**MAGUIRE PRODUCTS INC.**

---

**MLS Clear Vu®**

# **Model MLS Clear Vu®**

**Eight Component Vacuum Loading System**

**INSTALLATION • OPERATION • MAINTENANCE**

Original Instructions Manual  
Revision Date: March 11, 2022

Copyright © Maguire Products, Inc. 2022



# Maguire MLS Clear Vu®

## Copyright

© 2022 Maguire Products Inc.

The information contained within this manual including any translations thereof, is the property of Maguire Products Inc. and may not be reproduced, or transmitted in any form or by any means without the express written consent of Maguire Products Inc.

To every person concerned with use and maintenance of the Maguire MLS Clear Vu® it is recommended to read thoroughly these operating instructions. Maguire Products Inc. accepts no responsibility or liability for damage or malfunction of the equipment arising from non-observance of these operating instructions.

To avoid errors and to ensure trouble-free operation, it is essential that these operating instructions are read and understood by all personnel who are to use the equipment.

Should you have problems or difficulties with the equipment, please contact Maguire Products Inc. or your local Maguire distributor.

These operating instructions only apply to the equipment described within this manual.

## Manufacturer's Contact Information

Maguire Products Inc.  
11 Crozerville Road  
Aston, PA. 19014

Phone: 610.459.4300

Fax: 610.459.2700

Website: <http://www.maguire.com>

Email: [info@maguire.com](mailto:info@maguire.com)

## ***Accuracy of this Manual***

We make every effort to keep this manual as correct and current as possible. However, technology and product changes may occur more rapidly than the reprinting of this manual. Generally, modifications made to the dryer design or to the operation of the software are may not be reflected in the manual for several months. The date at the footer of this manual will indicate approximately how current this manual is. Likewise, your Maguire Loading System may have been produced at an earlier time and the information in this manual may not accurately describe your system since this manual is written for the current line of Maguire Loading System in production (as of the date in the footer). We always reserve the right to make these changes without notice, and we do not guarantee the manual to be entirely accurate. If you question any information in this manual, or find errors, please let us know so that we may make the required corrections or provide you with accurate information. Additionally, we will gladly provide you with an updated copy of any manuals you need at any time. We welcome comments and suggestions on ways we can improve this manual.

For additional information, or to download the latest copy of this manual or any other Maguire manual, please visit our website or contact us directly.

**On the Web at: [www.Maguire.com](http://www.Maguire.com)**

**Maguire Products Inc.  
Main Headquarters  
11 Crozerville Road  
Aston, PA 19014  
Tel: 610.459.4300  
Fax: 610.459.2700  
Email:  
[info@maguire.com](mailto:info@maguire.com)**

**Maguire Europe  
Tame Park  
Tamworth  
Staffordshire  
B775DY  
UK  
Tel: + 44 1827 265 850  
Fax: + 44 1827 265 855  
Email:  
[info@maguire-europe.com](mailto:info@maguire-europe.com)**

**Maguire Products Asia PTE LTD  
Main Office  
No. 15 Changi North Street 1  
#01-15, I-Lofts  
Singapore 498765  
Tel: 65 6848-7117  
Fax: 65 6542-8577  
[maqasia@maguire-products.com.sg](mailto:maqasia@maguire-products.com.sg)**

Please e-mail comments and suggestions to: [support@maguire.com](mailto:support@maguire.com)

## ***Table of Contents***

---

<b>PART 1</b>	<b>GETTING STARTED</b> .....	<b>6</b>
1.1	5 Year Warranty and Disclaimers.....	6
1.2	SAFETY Warnings.....	7
<b>PART 2</b>	<b>OPERATION</b> .....	<b>8</b>
2.1	<b>Installation</b> .....	<b>8</b>
	Receivers.....	8
	Level Sensor.....	8
	Vacuum/Power Station.....	13
	Controller.....	13
	Signal/Control Lines.....	14
	Air Supply.....	14
	Vacuum and Material Lines.....	14
2.2	<b>Check Out Procedure</b> .....	<b>16</b>
2.3	<b>Operation</b> .....	<b>16</b>
	Air Material Mix.....	16
	Receiver Load Time.....	16
	Filter.....	16
2.4	<b>Troubleshooting</b> .....	<b>18</b>
2.5	<b>Mechanical Adjustments</b> .....	<b>18</b>
2.6	<b>Setup Options – Summary List</b> .....	<b>19</b>
2.7	<b>Setup Options – Detailed Explanation</b> .....	<b>20</b>
2.8	<b>MLS Alarm Lights Explained</b> .....	<b>25</b>
2.9	<b>KIT-062C: MLS-10 DUAL CONTROLLER</b> .....	<b>26</b>
2.10	<b>KIT-062A: MLS-1/2/5 DUAL CONTROLLER</b> .....	<b>30</b>
<b>PART 3</b>	<b>General Information</b> .....	<b>34</b>
3.1	<b>Features</b> .....	<b>34</b>
	Vacuum Unit.....	34
	Positive Operation Of Valves.....	34
	Station Alarms.....	34
	Alarm Silence Button.....	34
	Station Timers.....	34
	Set Timers Button.....	34
	Filterless Receivers.....	34
	Unlimited Expansion.....	34
3.2	<b>Technical Support / Contact Information</b> .....	<b>38</b>

# 1 - Getting Started

---

## Warranty – Exclusive 5-Year

**MAGUIRE PRODUCTS** offers **THE MOST COMPREHENSIVE WARRANTY** in the plastics auxiliary equipment industry. We warrant each MAGUIRE Loading System manufactured by us to be free from defects in material and workmanship under normal use and service; excluding only those items listed below as 'excluded items'; our obligation under this warranty being limited to making good at our factory any Dryer which shall, within FIVE (5) YEARS after delivery to the original purchaser, be RETURNED intact to us, transportation charges PREPAID, and which our examination shall disclose to our satisfaction to have been thus defective; this warranty being expressly in lieu of all other warranties expressed or implied and of all other obligations or liabilities on our part, and MAGUIRE PRODUCTS neither assumes nor authorizes any other persons to assume for it any other liability in connection with the sale of its Dryers.



This warranty shall not apply to equipment repaired or altered outside MAGUIRE PRODUCTS INC. factory, unless such repair or alteration was, in our judgment, not responsible for the failure; nor which has been subject to misuse, negligence or accident, incorrect wiring by others, or installation or use not in accord with instructions furnished by Maguire Products, Inc.

Our liability under this warranty will extend only to equipment that is returned to our factory in Aston, Pennsylvania, PREPAID.

Please note that we always strive to satisfy our customers in whatever manner is deemed most expedient to overcome any problems they may have in connection with our equipment.

### Disclaimer

Processing conditions and materials vary widely from customer to customer and from product to product. Please be aware that it is IMPOSSIBLE for us to anticipate ALL conditions and requirements, or to be certain that our equipment will perform properly in all instances. You, the customer, must observe and verify the performance level of our equipment in your plant as part of your overall manufacturing process. You must verify to your own satisfaction that this level of performance meets your requirements. We CAN NOT be responsible for losses due to equipment not performing properly, even when due to equipment malfunction or design incorrect for your requirements; and/or for any consequential losses due to our equipment not meeting your requirements.

We will only be responsible to correct, repair, replace, or accept return for full refund if our equipment fails for any reason, or we have inadvertently misrepresented our equipment for your application.

**GETTING STARTED:  
PROCEED TO: SAFETY WARNINGS    NEXT PAGE**

## SAFETY WARNINGS



### Pinching Hazard:

Air operated slide gates on the bottom of each receiver are the only items that raise a safety concern. The air cylinders exert a force of about 70 pounds on closing. DO NOT reach into this area when cleaning the receiver, or from below when cleaning the hopper. DO NOT use your hands to clear obstructions.



**GETTING STARTED: PROCEED TO: INSTALLATION - NEXT PAGE**

## 2 – Operation

---

### Installation

#### YOUR SYSTEM consists of:

- One **FILTER/POWER STATION**, with central filter; dust collection container; vacuum blower/motor; 1, 2.5, 5 or 10 HP, all on wheels for portability.
- One **EIGHT STATION CONTROLLER**, to be placed on top of the power station, with outputs to each receiver and the power unit, alarms, and an on/off switch and status light for each station.
- Up to eight **RECEIVERS**, filterless, 10 pound capacity, clear, with level sensor and vacuum sequencing valve built in.

If your application is "beside the press" using a "pick-up" lance, the following kit is provided for each receiver.

- 1 Lance with two 2" hose clamps in box.
- 12' flexible material hose, 1.5" ID

#### Each CUSTOMER must supply, or purchase separately:

Vacuum and material line using 1.5", 2", or 2.5" tubing, (steel, aluminum, or PVC), and tees and elbows as required.

#### 1. RECEIVERS:

Mount receivers over the hopper compartments you wish to load.

Receivers are sized to fit over round openings as large as 10 inches in diameter. Larger openings require adaptor plates. Openings smaller than 8" diameter must be enlarged using the drawings provided on the next page.

The 8" x 8" square bolt pattern allows you to select 4 orientations for the receiver.

Select an orientation so the VACUUM line is located best for your installation. The material inlet line swivels 180 degrees

#### 2. LEVEL SENSOR:

The LEVEL SENSOR is mounted into the base of the receiver. It is placed directly under the flow of material. If you select another location, be sure that it is not uncovered before material is completely empty from the receiver.

The sensor LED is ON when COVERED, OFF when UNCOVERED. See ADJUSTMENTS, page 18, if you suspect it needs adjustment.



**MAGUIRE**  
 11 Crozerville Road  
 Aston, PA, USA  
 610-459-4300  
 Fax 610-459-2700

MAGUIRE LOADER RECEIVER  
 MOUNTING OPTIONS

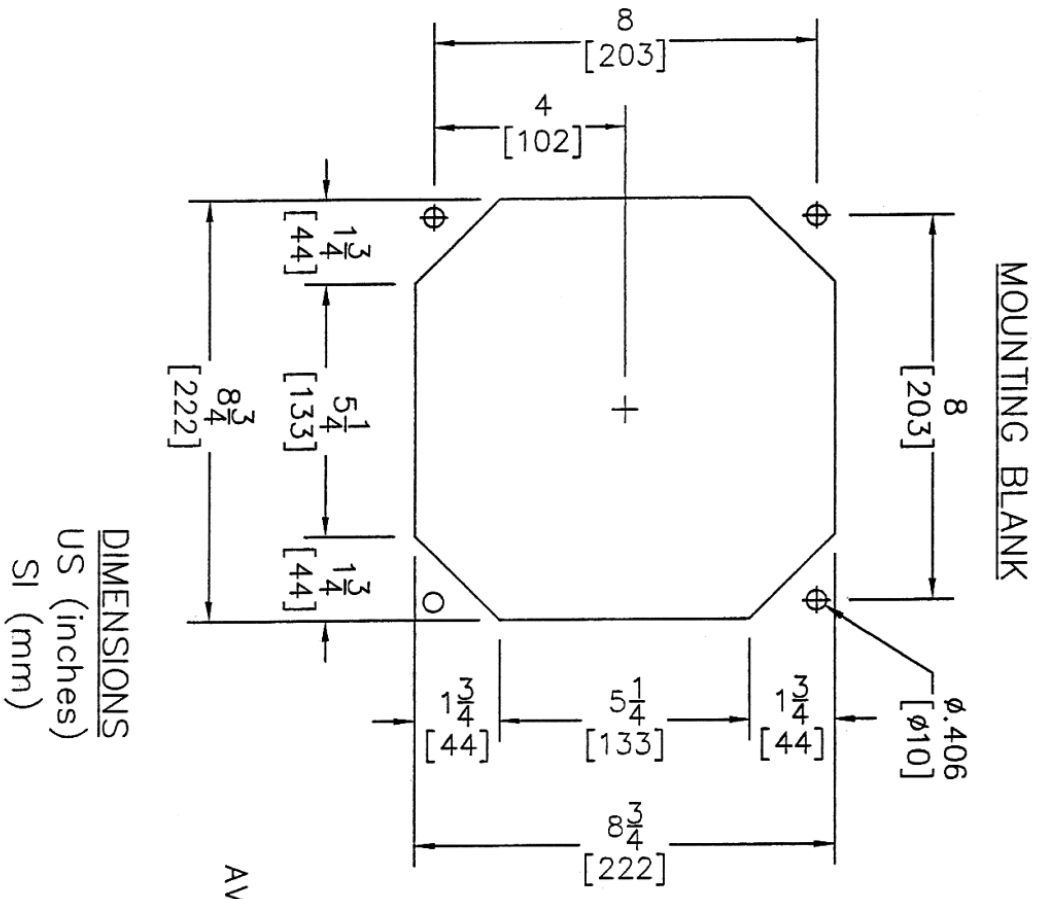

DIMENSIONS  
 US (inches)  
 SI (mm)

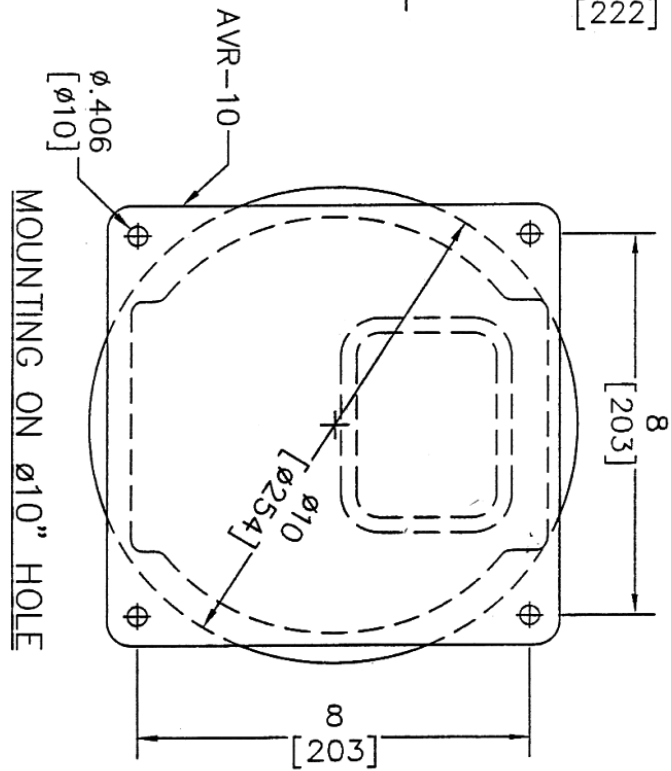
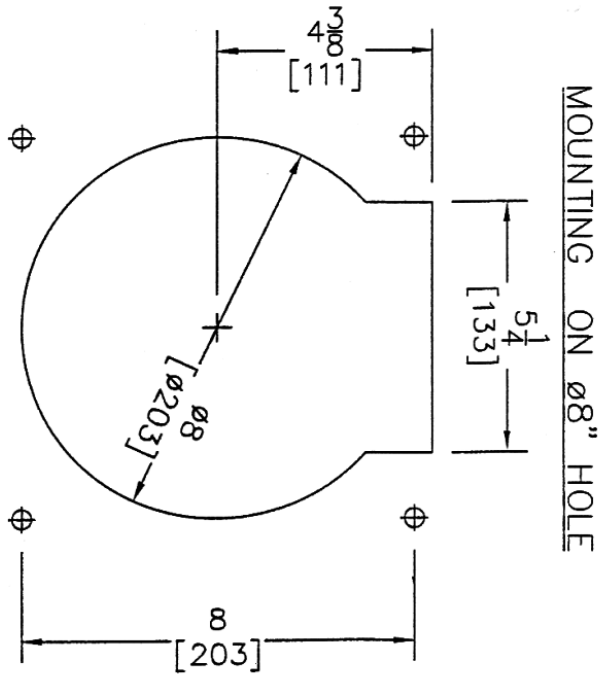

# AVR-10 Airline Connections

- Upper Solenoid Port [A]  
connects to:
- End of Bottom Air Cylinder
  - Nose of Upper Air Cylinder
- Lower Solenoid Port [B]  
connects to:
- Nose of Bottom Air Cylinder
  - End of Upper Air Cylinder

Solenoid Air Intake uses a Tee Fitting in order to daisy chain the receivers. The last receiver requires a plug.

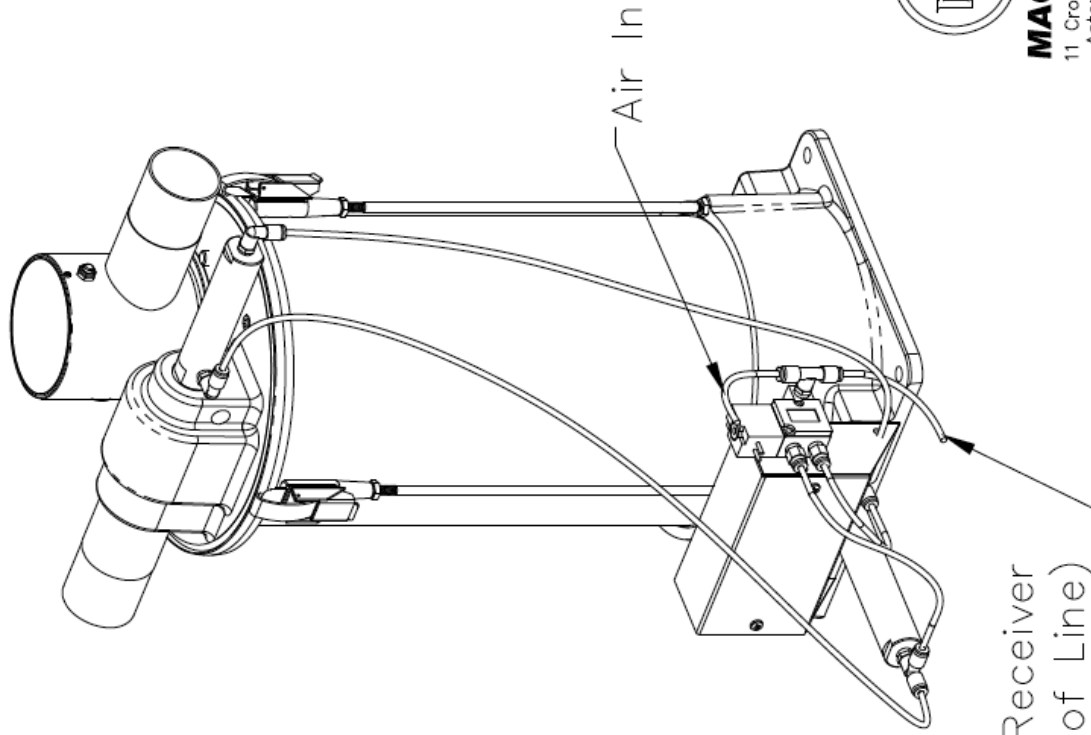

**MAGUIRE**  
11 Crozerville Road  
Aston, PA, USA  
610-459-4300  
Fax 610-459-2700

5/24/2018

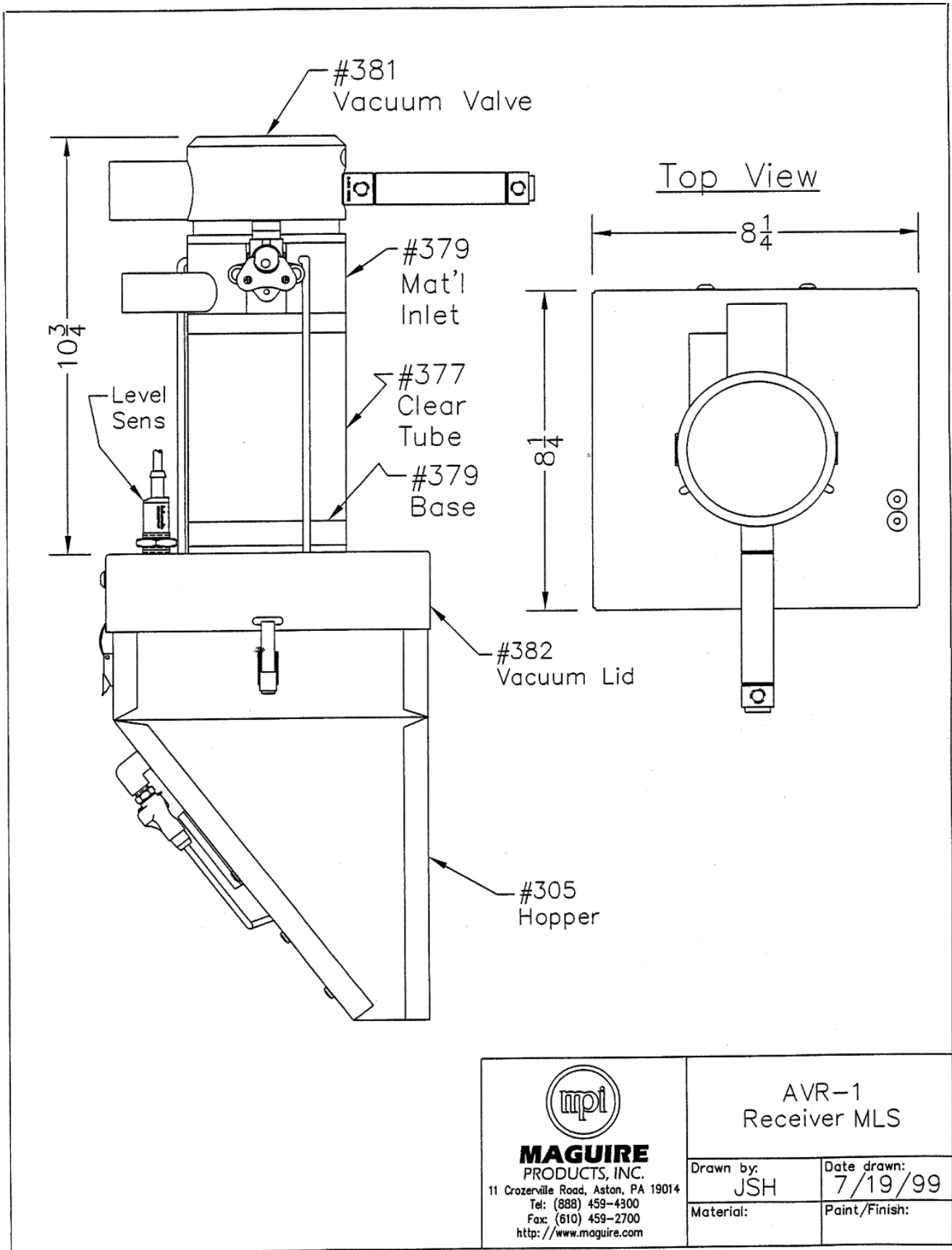

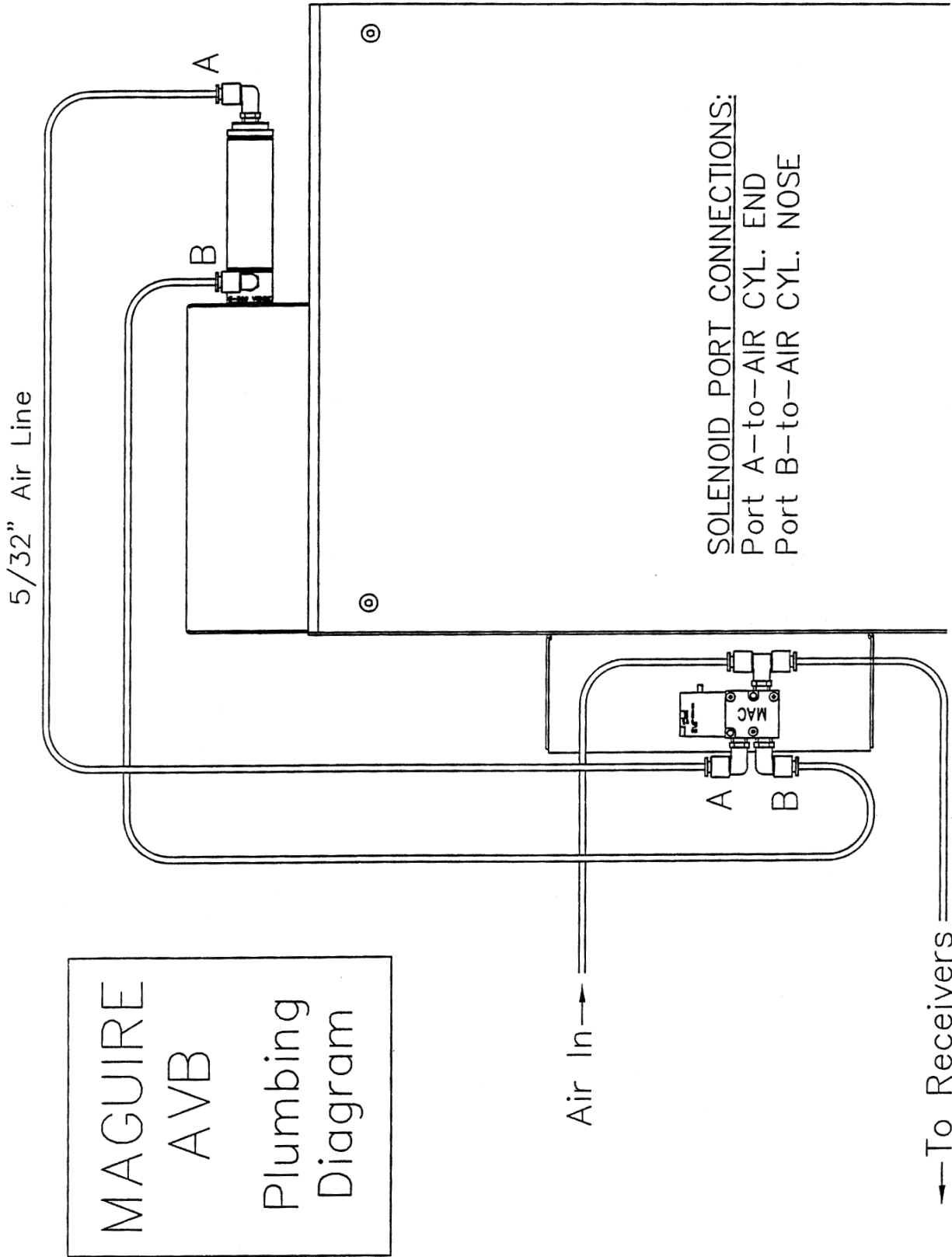

### 3. VACUUM/POWER STATION:

Position power station for easy access to the filter compartment and controller.

#### Consider the following:

##### a. 1 HP units:

1 HP units require a STRONG 120 volt power source. DO NOT use an extension cord, unless it is 12 gauge or better. Be sure the outlet is rated for 20 amps minimum.

On startup, the blower requires a surge of over 40 amps and should be able to pull this high current to start properly. If supply wire size is not adequate, the blower will be unable to pull full startup amperage. The higher the initial amp draw, the faster the motor reaches full speed and, subsequently, the cooler it runs.

If the blower does not come up to full speed within 6 seconds power supply is not as strong as it should be.

Slow starting may be OK, depending on the duty cycle of the blower. 120 volt single phase blower motors have automatic overheat protection and will stop operating if they become too hot due to an inadequate power supply. If you experience this problem, read SETUP OPTIONS, Routine 5.

##### b. 2.5, 5 and 10 HP units:

These units require 3 phase current. 2.5 and 5 HP are 230 or 460 volt. 10 HP is 460 volt only. Typically 3 phase motors reach full speed in a fraction of a second.

Unless you specified otherwise, we have wired and tested these units for 460 volt, 3 ph. If you rewire them for 230 volts, you will have to change the overload protection heaters in the motor starter for higher amp draw.

### 4. CONTROLLER:

Place the controller in the tray provided on top of the Filter/Power station. Secure the controller with the screw provided in the back of the tray. Hand tighten only.

Plug the CONTROLLER into the 120 volt outlet on the back of the Filter/Power station.



#### NOTE

A single controller controls 8 stations. There is a Dual Controller Option that uses two controllers (Main and Follower) to control up to a maximum of 16 stations.

## 5. SIGNAL/CONTROL LINES - 24 VOLT:

- a. Each receiver has a 30-foot signal/control cable. These plug into the back of the controller. Receivers can be plugged into any one of the eight station "ports". Connect receivers in a number sequence that makes sense for your installation.



24-volt extension cables are available if required to reach the controller. Connectors have 7 pins. Earlier units had 4 pins. If your plugs don't match the receptacles, call us.

- a. A short cable comes from the junction box on the back of the Vacuum Power Station. Plug this into the right side of the controller.



If you have the Dual Controller Option, plug the vacuum station cable into the Main controller.

## 6. AIR SUPPLY:

The receivers and the power station both require air pressure to operate. When mounted on a Weigh Scale Blender, receivers can get their air supply from the extra "pressure gauge" port on the blender's air pressure regulator.

Each receiver has a tee connector to allow chaining the air supply to another receiver. Receivers near each other can be chained together.

The Power station also requires an air line. This may be supplied independently or by running an air line from one of the receivers to the Vacuum Power Station. It is easy to bundle an air line with one of the 24 volt signal lines that runs from each receiver to the power station.

## 7. VACUUM AND MATERIAL LINES - SIZE AND MAXIMUM DISTANCE:

### Recommended Tubing Sizes and Maximum Distance:

Model	Line Diameter	Vacuum Line Actual Distance (ft)	Material Line Equivalent Distance (ft)
MLS-180	1½"	100	60
	2"	100	Do not use 2"
MLS-280	1½"	150	150
	2"	200	Do not use 2"
MLS-580	2"	250	250
MLS-1080	2½"	350	300
	3"	400	350

## LOADING OVER LONGER DISTANCES:

When calculating the EQUIVALENT LENGTH of the material line distance, you must add for vertical runs, elbows, and flexible tubing. All of these reduce conveying efficiency.

### Equivalent Distance for calculating material lines

1 foot horizontal	=	1 equivalent foot
1 foot vertical	=	2 equivalent feet
1 foot flex hose	=	3 equivalent feet
1 foot radius elbow	=	4 equivalent feet
2 foot radius elbow	=	8 equivalent feet

Radius for elbows or sweeps should be 8 times the tube diameter. Example: 2" diameter tube = 16" radius.



**NOTE**

### Installation Recommendations:

- Use aluminum tubing for vacuum lines and longer material line runs.
- Minimize use of flexible tubing for material line.
- Use hose clamps to secure all flex tubing
- Use tees as required for vacuum lines

**REMEMBER:** Performance is reduced by:  
Inadequate diameter line, Longer length lines, Elbows, and corrugated flex tubing, Restrictions or "neck down" points, Clogged filters, Vacuum leaks.

## LOADING BESIDE THE PRESS:

Twelve foot lengths of flexible hose are provided for beside-the-press conveying of material. Connect one length to each receiver.  
Each line should connect to a pick-up lance in a barrel or gaylord.  
Use hose clamps provided to secure the lines.

## 8. CONVEYING RATES OVER EQUIVALENT DISTANCES

Following are conveying rates over equivalent distances, based on actual testing, conveying styrene pellets.

		40 ft	90 ft	140 ft	240 ft
MLS-180	1.5" line	1400	--	--	--
MLS-280	2" line	2400	1000	--	--
MLS-580	2" line	3000	2500	1850	1200
MLS-1080	2.5" line	6000	5000	3650	2400

**REMEMBER:** Performance is reduced by:  
Inadequate diameter line, Longer length lines, Elbows, and corrugated flex tubing, Restrictions or "neck down" points, Clogged filters, Vacuum leaks, Bulk density and flow characteristics of the material.

## CHECK OUT PROCEDURE

1. Confirm all air line connections are correct:

With POWER OFF, and AIR PRESSURE connected:

- All receiver slide gates should be OPEN, allowing material to flow out of the receiver.
- The vacuum valve on top of each receiver should be CLOSED, extended, blocking the vacuum line.
- The vacuum relief valve on top of the POWER UNIT should be OPEN.

2. Turn on main power. Confirm switch light is lit.
3. Turn each station on one at a time, testing each separately.

Switches with receivers CONNECTED will light and blink slowly indicating the sensor is calling for material. With these stations, the blower will start.

If a single station does not start:

Be sure the sensor is in place.

Be sure the sensor is not covered.

Be sure the signal cord is properly connected.

Adjust sensor if necessary.

Stations NOT connected to receivers will light, but will NOT start the blower.

## OPERATION

1. Turn power ON.
2. Turn on each station you wish to load.

The controller will sequence through all stations that are turned on until all hoppers are full, sensors covered.

The blower motor remains on 10 minutes after all stations are satisfied. The vacuum relief valve, on top of the filter/power station, allows air to circulate through the vacuum blower during any "idle" time.

If there is no demand for loading after 10 minutes, the blower shuts down. (This delay shutdown time is adjustable).

## AIR MATERIAL MIX:

The mix of air with material has a dramatic effect on conveying rate. You should adjust this for each receiver.

Our pick up lances incorporate a disk to regulate air flow.

Our vacuum take-off assemblies (VTA's) allow air adjustment by rotating the probe, or rotating an air regulator sleeve.

While each station is loading watch the flow of material into the CLEAR-VU receiver. Adjust air flow for best smooth flow.

**RECEIVER LOAD TIME:**

As each receiver fills, observe the material level in the receiver. Load time is correct if the station stops loading when about 75 percent full, or just below the MAGUIRE logo.

If the load time is NOT correct, reset the timer for that station.

To RESET THE TIMER for one station:

1. PRESS and HOLD the "SET LOAD TIME" button AFTER station has started to load. Load time can be set ONLY while station is loading.
2. RELEASE the button when correct level is reached. The correct time is now set.

For very dusty materials, fill receiver to a LOWER level. This will help keep the filter clear.

LOW fill levels are safer than filling to a level that is too HIGH.

**FILTER:**

Individual stations contain only a very coarse screen filter. The filter(s) in the power station traps all dust before it can reach the vacuum pump.

To check filter:

1. Turn Controller power OFF to stop blower motor.
2. Open the door on the front of the Filter/Power station. Release the lift handle(s). Lower the filter bucket(s).
3. Remove container. Empty if necessary.
4. Examine the filter. Clean if necessary. If the container has an excessive amount of material in it, you may be loading a receiver to too high a level. Shorten load times so receivers do not overflow.

Smaller loads will NOT significantly reduce conveying rate. Stations simply load more frequently.

For very dusty materials, adjust fill time to fill to a LOWER level. This will help keep the filter clear.

5. Lift container platform back into place. BE SURE top edge of bucket engages gasket properly for vacuum.

**TOGGLE SWITCH LIGHTS indicate:**

SOLID ON:	FULL
SLOW BLINKING:	LOW
RAPID BLINKING:	LOADING
VERY FAST BLINKING:	ALARMING, failed to cover sensor last cycle.

## TROUBLESHOOTING

If loading is a problem:

1. Be sure: Filter dust collector is "in place" and vacuum tight.
2. Be sure: The material fill "turret" in the top of each receiver is properly in place.
3. Be sure: Air pressure is reaching all the cylinders as well as the Vacuum Blower Station. Without air pressure, the system will not develop vacuum.
4. Be sure: All signal lines are connected properly at the controller.
5. Be sure: The level sensor, at the bottom of each receiver, is adjusted correctly so it does not send back a false "covered" signal. See ADJUSTMENTS to adjust sensor.
6. Check Filter: If the container has an excessive amount of material in it, you may be loading a receiver to too high a level. Shorten load times so receivers do not overflow.

Smaller loads do NOT significantly reduce conveying rate.  
Stations simply load more frequently.

7. Excessive high vacuum will overheat the blower. A thermal switch is provided in the exhaust air stream, which trips out at 190F, keeping the air bypass valve open. This cools the blower, but loading cannot occur during this time. If this happens, check main filter and receiver screens for blockage.

## MECHANICAL ADJUSTMENTS

**SENSOR** There is a small screw in the rear of the sensor to adjust the sensitivity of the sensor. Turning it Clockwise (CW) will increase sensitivity. CCW will decrease. (Some sensors have a plug in front of the adjustment screw, which must first be removed. The adjusting screw is recessed.)

The LED light is ON when the sensor is COVERED. It is OFF when UNCOVERED.

**To adjust:** Make sure sensor is UNCOVERED.  
Turn screw inward (CW) until the LED goes ON.  
Turn outward slowly (CCW) until it just comes OFF.  
Turn 1/4 turn more (CCW).

Now TEST for correct operation.  
Cover with hand, LED should light.  
Uncover, it should go OFF.

## SETUP OPTIONS - SUMMARY LIST

Select ROUTINE number, hold "SET TIMER", and turn POWER ON.

ROUTINE 0.

Display Software Version.

Lighted Switch:	1	2	3	4	5	6	7	8
Add Values:	1	2	4	8	16	32	64	128

Power OFF to EXIT

ROUTINE 1.

Reset Default Load Times - Selected Stations.  
Select Stations to Reset, Press "SET TIMER".

ROUTINE 2.

Controller Address - Main / Follower Designation

Lighted Switch:	1	2	3	4	5	6	7	8
Add Values:	1	2	4	8	16	32	64	128

Enter NEW ADDRESS, Press "SET TIMER".  
Switches 7 and 8 on, designate Main.  
Switches 1, 7, and 8 on, designate Follower.

ROUTINE 3.

Disable / Enable Alarm - Selected Stations.  
Select Stations to ALARM, Press "SET TIMER".

ROUTINE 4.

Delay the Retry Time - Selected Stations  
Select Stations to change, Press "SET TIMER".  
Select 0 to 8 minute delay, Press "SET TIMER".

ROUTINE 5.

Set Blower OFF DELAY Time, minutes.

Select:	1	2	3	4	5	6	7	8
Delay=	1	2	3	5	10	15	20	30

Press "SET TIMER".

ROUTINE 6.

Set Delay before loading starts.

Lighted Switch:	1	2	3	4	5	6	7	8
Add Values:	1	2	4	8	16	32	64	128

Enter NEW DELAY time, Press "SET TIMER".

ROUTINE 7.

Set number of retries before alarm (When Routine 3 is enabled).

ROUTINE 8.

DISABLE / ENABLE filter alarm.

ROUTINE 12345678.

CLEAR to default values.

Setup Options - Detailed explanations on the following pages . . .

## SETUP OPTIONS - DETAILED EXPLANATIONS

There are several SETUP routines that allow you to customize your controller for your installation.

### ROUTINE 0. Display current software version.

Turn POWER OFF.

Turn ALL STATION switches OFF.

While pressing "SET LOAD TIME" button, turn POWER ON.

Hold for 3 seconds, while all lights blink rapidly.

Release when blinking stops.

The lighted switches represent the software version number in binary format.

For switch numbers:	1	2	3	4	5	6	7	8
Assign values of:	1	2	4	8	16	32	64	128

Add up the values of the lighted switches to obtain the version number.

To EXIT, turn power off.

### ROUTINE 1. Reset selected stations to default load times.

Turn POWER OFF.

Turn STATION 1 switch ON, all others OFF.

While pressing "SET LOAD TIME" button, turn POWER ON.

Hold for 3 seconds, while all lights blink rapidly.

Release when blinking stops.

Turn ON all stations you want to reset.

Turn OFF all stations you want unchanged.

Press and hold "SET LOAD TIME" button for 1 second.

All lights will flash and then go off.

Release button to resume normal operation.

### ROUTINE 2. Enter an address for this controller.

If you are using the Dual Controller Option two controllers are linked together with a specially wired communication cable that we supply. This cable connects the communication ports of the controllers. There can only be one "Main" controller, the other one is the "Follower". The address of the Main must be 78. The Main runs the blower. The blower control cable is connected to the Main. Single units are always addressed as "Main"; address 78. The Follower is addressed with a 1 in front (178).

Here is the routine to change the address.

Turn POWER OFF.

Turn STATION 2 switch ON, all others OFF.

While pressing "SET LOAD TIME" button, turn POWER ON.

Hold button until all lights stop blinking (about 3 secs).  
Release when blinking stops.

The lighted switches represent the current controller address.  
Normally, switches 7 and 8 will be lit.

To CHANGE this address:  
Turn ON the correct combination of switches for the new address.  
Turn OFF all other switches.  
For a Follower controller, set switch 1, 7, and 8 on, others off.

Press and hold "SET LOAD TIME" button for 1 second.  
All lights will flash and then go off.  
Release button to resume normal operation.

### **ROUTINE 3. Disable / Enable alarms on selected stations.**

Turn POWER OFF.  
Turn STATION 3 switch ON, all others OFF.  
While pressing "SET LOAD TIME" button, turn POWER ON.  
Hold for 3 seconds, while all lights blink rapidly.  
Release when blinking stops.

Turn ON all stations you want to alarm when they fail to load.  
Turn OFF all stations you do NOT want to alarm.

Press and hold "SET LOAD TIME" button for 1 second.  
All lights will flash and then go off.  
Release button to resume normal operation.

### **ROUTINE 4. Delay the retry time for selected stations**

This option allows you to delay the retry of a single station or stations from 1 to 8 minutes. This is useful when using the system to keep a grinder evacuated, without having the unit cycle continuously. When the source of material is limited, you know the sensor will seldom be satisfied. For the same reason continuous running is unnecessary. This option allows a station to cycle less frequently.

Turn POWER OFF.  
Turn STATION 4 switch ON, all others OFF.  
While pressing "SET LOAD TIME" button, turn POWER ON.  
Hold for 3 seconds, while all lights blink rapidly,  
Release when blinking stops.

Turn ON all stations you want to change.  
You may change more than one, but all you select will be changed to the same new delay time.  
Turn OFF all stations you do NOT want to change.

Press and hold "SET LOAD TIME" button for 1 second.

All lights will flash and then the selected stations will light.

Now turn OFF all switches.

Now turn ON one switch to equal the number of minutes the selected stations will stay idle before loading again. This can be from 1 to 8 minutes.

Turn OFF all other station switches.

Having ALL stations OFF will cause the selected stations to reset to normal operation of running with no delays.

Press and hold "SET LOAD TIME" button for 1 second.

All lights will flash and then the selected stations will light.

Release button to resume normal operation.

#### **ROUTINE 5. Set blower OFF DELAY time.**

When all stations are satisfied the blower shuts down. However, if a station calls for material within a set time period (default is 10 minutes), then the next time all stations are satisfied, the blower will keep running. This is due to anticipation that the blower will be called on again within the time period. Therefore it is kept running.

By the same token, if the blower is not required within the time period, it shuts down and the next time all stations are satisfied, the blower shuts off immediately. This is due to anticipation that the blower will not be called on again within the time period. Therefore it is shut down immediately.

The 10 minute time period is adjustable.

Turn POWER OFF.

Turn STATION 5 switch ON, all others OFF.

While pressing "SET LOAD TIME" button, turn POWER ON.

Hold for 3 seconds, while all lights blink rapidly.

Release when blinking stops.

Turn ON a single station switch to indicate the time delay you want. Turn OFF all other stations

Switch number: Will produce this delay:

1	1	minute
2	2	
3	3	
4	5	
5	10	
6	15	If more then one switch is on,
7	20	or no switches are on,
8	30	no change will occur.

Press and hold "SET LOAD TIME" button for 1 second.  
 All lights will flash and then go off.  
 Release button to resume normal operation.

**ROUTINE 6. Enter a new delay time for starting to load.**

When the sensor in a receiver becomes uncovered, the loader will usually begin loading that station right away... zero delay. When station loading must be synchronized with a blender dispense operation, as in the case of our CVB style blenders with Synchronized loaders, then we must delay the start of loading for a short time, usually about 10 seconds, to be sure the dispense is complete. Loading with this style receiver interferes with dispensing, and dispensing also interferes with loading. Loaders are normally shipped with zero delay. When synchronized loading is required, change this delay to 10 seconds.

Here is the routine to change the address.

Turn POWER OFF.  
 Turn STATION 6 switch ON, all others OFF.  
 While pressing "SET LOAD TIME" button, turn POWER ON.  
 Hold for 3 seconds, while all lights blink rapidly.  
 Release when blinking stops.

For switch numbers:	1	2	3	4	5	6	7	8
We assign values of:	1	2	4	8	16	32	64	128

The lighted switches represent the current delay. Normally, no switches are lit.

To CHANGE this delay:  
 Turn ON the correct combination of switches for the new delay time in seconds.  
 Turn OFF all other switches.  
 For 10 seconds, turn on switch 2 and 4 (2+8=10)

Press and hold "SET LOAD TIME" button for 1 second.  
 All lights will flash and then go off.  
 Release button to resume normal operation.

**ROUTINE 7. Set number of retries before alarm (When Routine 3 is enabled)**

Turn POWER OFF  
 Turn STATION 7 switch on, all others off  
 While pressing the "SET LOAD TIME" button, turn POWER ON  
 HOLD button until all lights stop blinking, then release.  
 Turn off switch 7.  
 Turn on one switch for amount of retries (1 to 8 retries), all others off.

Press and hold the "SET LOAD TIME" button for 1 second.  
 All lights will flash and then go off.  
 Release button to resume normal operation.

**ROUTINE 8. DISABLE / ENABLE filter alarm.**

Turn POWER OFF

Turn STATION 8 switch on, all others off

While pressing the "SET LOAD TIME" button, turn POWER ON  
HOLD button until all lights stop blinking, then release.

Place Station 8 switch in position. Off to disable, ON to enable

Press and hold the "SET LOAD TIME" button for 1 second.

All lights will flash and then go off.

Release button to resume normal operation.

Alarm Condition.

1. When turning power on if circuit for detecting filter is not present the alarm will sound and the switches will blink between the top row 1256 and bottom row 3478. This normally indicates that the filters are not installed properly.

Turn power off and fix the problem.

2. After power has been turned on and filter circuit was present at anytime the filter circuit becomes not present the alarm will sound and the switches will blink between the left side 1234 and right side 5678. This normally indicates a clogged filter.

Turn power off and fix the problem

**ROUTINE 12345678. CLEAR ALL.**

Clear ALL programmed data and reset all numbers and timers to original default values.

Turn POWER OFF.

Turn ALL STATIONS ON.

While pressing "SET LOAD TIME" button, turn POWER ON.

Hold button until all lights stop blinking (about 12 secs).

Release when blinking stops.

Turn power off then on again.

All values, flags, timers, etc. are now cleared and set to their original programmed default values.

# MLS Alarm Lights Explained

## MLS ALARM LIGHT PATTERNS

### HOW TO

#### NO FILTER PRESENT CLOGGED FILTER

TOP 4 LIGHTS BLINK ON FOR 1/2 SECOND

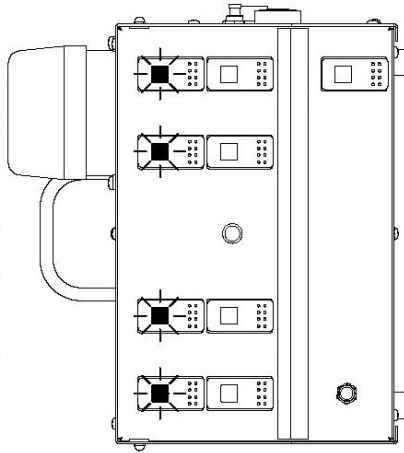

THEN

BOTTOM 4 LIGHTS BLINK ON FOR 1/2 SECOND

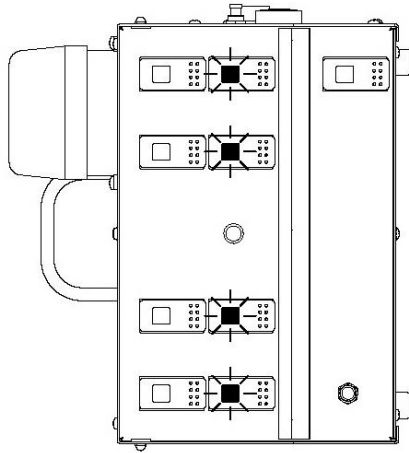

#### LEFT 4 LIGHTS BLINK ON FOR 1/2 SECOND

LEFT 4 LIGHTS BLINK ON FOR 1/2 SECOND

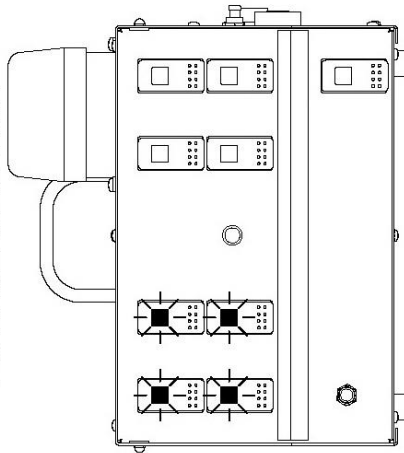

THEN

RIGHT 4 LIGHTS BLINK ON FOR 1/2 SECOND

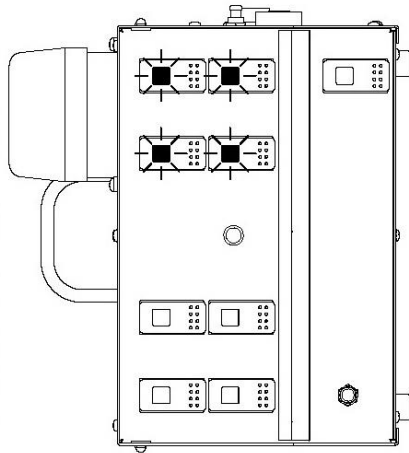

#### HANDLE ALARMS

1: PRESS SILENCE ALARM BUTTON TO SILENCE AUDIBLE ALARM (THIS DOES NOT RESET THE ALARM)

2: CHECK CONTROLLER FOR ALARM PATTERN

3: FIX PROBLEM

4: TO RESET ALARM, CYCLE POWER

Maguire P/N: 1109

## **KIT-062C: MLS-10 DUAL CONTROLLER, 110V**

### **PARTS LIST**

P/N	QTY	DESCRIPTION
AVC-81	1	MLS FOLLOWER Controller, 110v
107-avc	1	Right End Plate with following installed
Ew04	1	Ribbon cable with DB9 Male Connector
Ehcc6	1	DB9 Female / Female Cable

### **DESCRIPTION**

This kit allows a dual MAIN – FOLLOWER controller setup in which the customer can piggyback a second controller to their existing Maguire Loading System to allow a total of 16 receiver outputs.

Included in this kit is a complete MLS controller set up as the FOLLOWER controller and the parts necessary to convert the customer's existing controller to the MAIN controller.



**WARNING:** Disconnect power to controller before servicing. Failure to disconnect power can cause injury or death.

## MAIN CONTROLLER MODIFICATION

### 1. Remove existing controller from loading station.

- A. Tag and disconnect all receiver cables from back of controller.
- B. Disconnect power and signal cable from loading station electric box.

### 2. Open up existing controller.

- A. Remove (10) screws holding lid on controller. Note that the lid is connected to controller by 2 wires running to strobe light. The wires are long enough so that lid can be tilted back until behind controller and still be connected to strobe light.

- B. Remove (2) screws fastening endplate to base.

- C. Remove (3) screws on bottom of base fastening front face to controller. Tilt front face down for easier access to control board.

**NEW ENDPLATE WITH COMPONENTS INSTALLED**

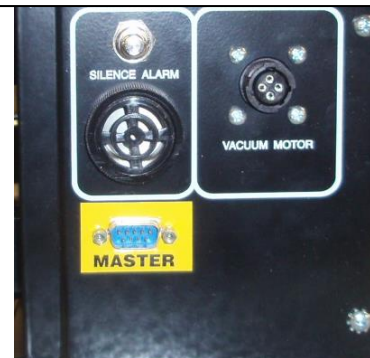

### 3. Remove items from old endplate.

- A. Silence alarm button
- B. Alarm buzzer
- C. Vacuum motor 4-pin receptacle

### 4. Transfer items to new endplate supplied with kit.

- 5. Plug ribbon cable from DB9 connector into 10-pin connector on left side of control board.

### 6. Close up controller.

- A. Reinstall controller front face.
- B. Install new endplate to controller
- C. Reinstall lid to controller.

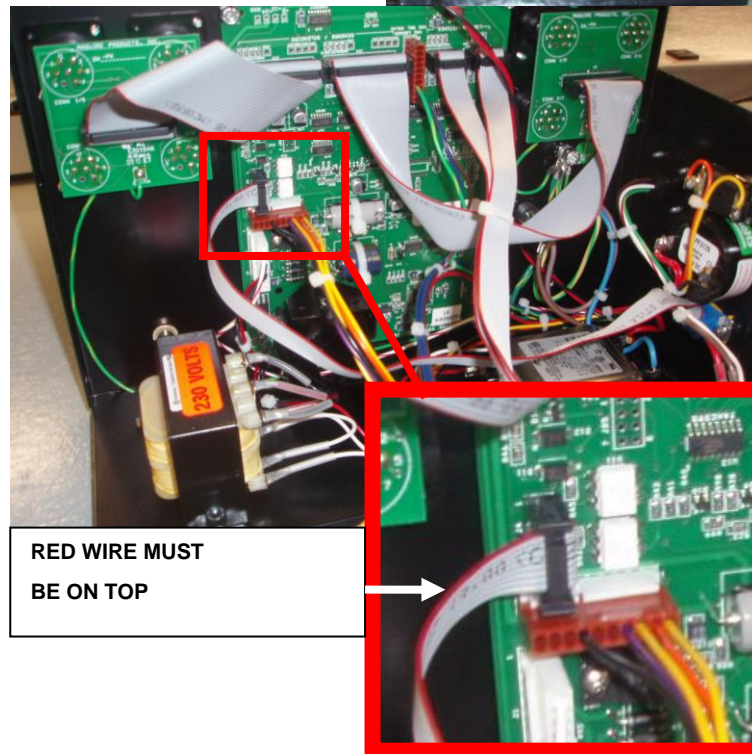

**RED WIRE MUST BE ON TOP**

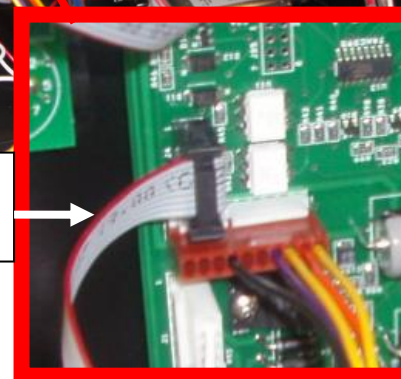

## **CONTROLLER ARRANGEMENT**

Looking at the loading system from the front...

### **7. Install MAIN controller on left tray.**

- A. Plug power cord into motor starter box.
- B. Reconnect "VACUUM MOTOR" cord to connector in endplate.
- C. Plug in the YELLOW end of the DB9 cable supplied in the kit into the DB9 connector on the endplate.
- D. Reconnect the correct receiver cables to the back of the controller.

### **8. Install FOLLOWER controller on right tray.**

- A. Plug Power cord into Motor Starter Box.
- B. Connect the gray end of DB9 cable to connector in endplate.
- C. Connect the new receiver cables to the back of the controller.

**IMPORTANT: THE YELLOW END OF THE DB9 CABLE SHOULD ALWAYS BE PLUGGED INTO THE "MAIN" CONTROLLER.**

## **SETUP OF MAIN AND FOLLOWER CONTROLLERS**

This is routine #2 in the MLS Manual.

You will need to do step 11 for each controller to enter the change address routine, then depending on the controller either jump to step 12 or 13.

### **9. Enter address of MLS controllers**

- A. Turn POWER OFF.
- B. Turn SWITCH #2 ON, all others OFF.
- C. Press and hold "SET LOAD TIME" button, turn POWER ON.
- D. Hold for 3 seconds, while all lights blink rapidly.
- E. Release when blinking stops.

### **10. To enter address of MAIN controller.**

(note that Main controller should already have this address)

- A. Turn ON switches 7 and 8.
- B. Turn OFF all other switches.
- C. Press and hold "SET LOAD TIME" button for 1 second.
- D. All lights will flash and then go off.
- E. Release button to resume operation

### **11. To enter address of FOLLOWER Controller.**

- A. Turn ON switches 1, 7 and 8.
- B. Turn OFF all other switches.
- C. Press and hold "SET LOAD TIME" button for 1 second.
- D. All lights will flash and then go off.
- E. Release button to resume operation.

## KIT-062A: MLS-1/2/5 DUAL CONTROLLER, 110V

### PARTS LIST

P/N	QTY	DESCRIPTION
AVC-81	1	MLS <b>Follower</b> Controller, 110V
107-avc	1	Right End Plate-with following installed:
ew04	1	-Ribbon Cable w/ DB9 Male Connector
ehcc6	1	DB9 Female / Female Cable
510	1	Controller Tray
1781-B	1	Follower Controller Mount
sb4-12	4	Button Head Cap Screw, 1/4-20 x 3/4"
sn4	2	Hex Nut, 1/4-20
snn4	4	Nylok Nut, 1/4-20

### DESCRIPTION

This kit allows a dual Main – Follower controller setup in which the customer can piggyback a second controller to their existing Maguire Loading System to allow a total of 16 receiver outputs.

Included in this kit is a complete MLS controller set up as the Follower controller, the parts necessary to convert the customer's existing controller to the Main controller, and new controller tray assembly and hardware.



**WARNING:** Disconnect power to controller before servicing. Failure to disconnect power can cause injury or death.

## MAIN CONTROLLER MODIFICATION

### 12. Remove existing controller from loading station.

- A. Tag and disconnect all receiver cables from back of controller.
- B. Disconnect power and signal cable from loading station electric box.

### 13. Open up existing controller.

- A. Remove (10) screws holding lid on controller. Note that the lid is connected to controller by 2 wires running to strobe light. The wires are long enough so that lid can be tilted back until behind controller and still be connected to strobe light.
- B. Remove (2) screws fastening endplate to base.
- C. Remove (3) screws on bottom of base fastening front face to controller. Tilt front face down for easier access to control board.

**NEW ENDPLATE WITH COMPONENTS INSTALLED**



### 14. Remove items from old endplate.

- A. Silence alarm button
- B. Alarm buzzer
- C. Vacuum motor 4-pin receptacle

### 15. Transfer items to new endplate supplied with kit.

- 16. Plug ribbon cable from DB9 connector into 10-pin connector on left side of control board.

### 17. Close up controller.

- A. Reinstall controller front face.
- B. Install new endplate to controller
- C. Reinstall lid to controller.

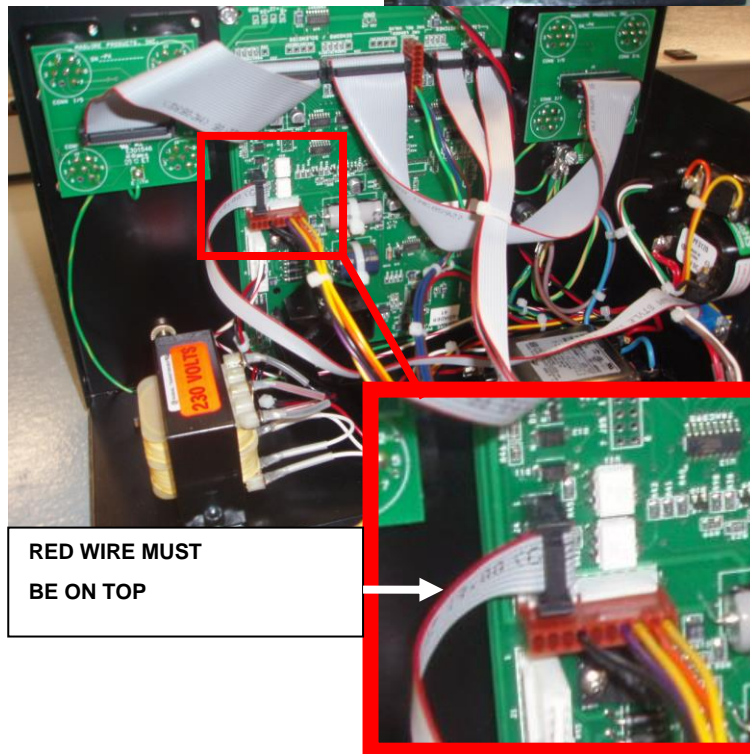

**RED WIRE MUST BE ON TOP**

## TRAY ASSEMBLY

18. Unfasten and remove existing controller tray from top of the loader.

19. Install new controller tray assembly as shown.

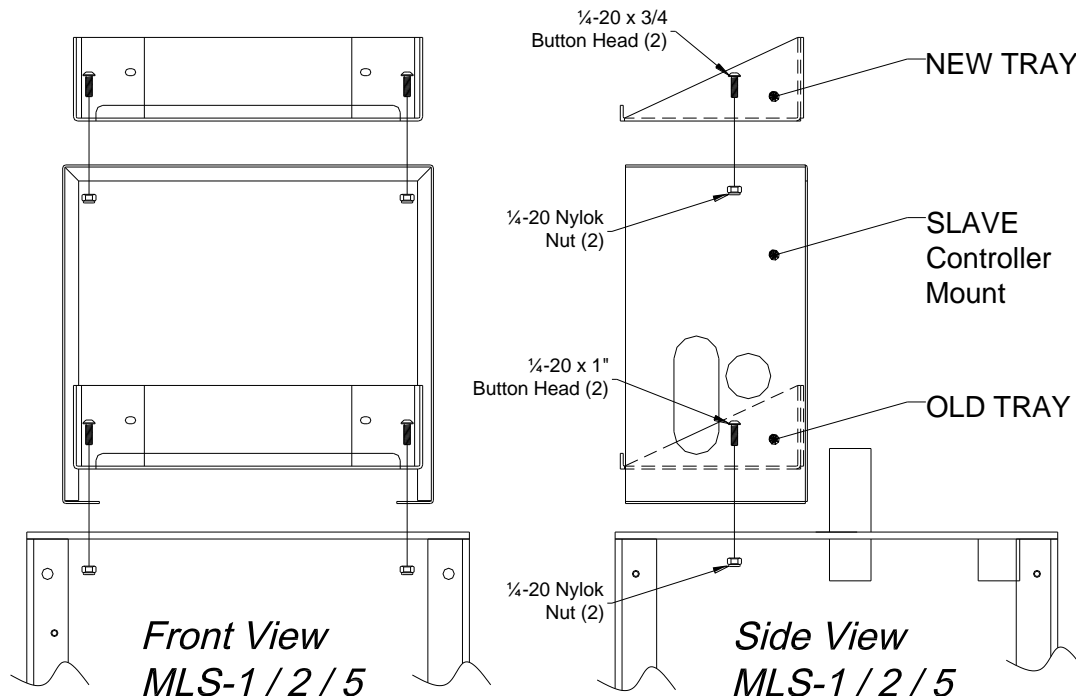

20. Install MAIN controller on bottom tray.

- A. Plug power cord into motor starter box.
- B. Reconnect "VACUUM MOTOR" cord to connector in endplate.
- C. Plug in the YELLOW end of the DB9 cable supplied in the kit into the DB9 connector on the endplate.
- D. Reconnect the correct receiver cables to the back of the controller.

21. Install FOLLOWER controller on top try.

- A. Plug Power cord into Motor Starter Box.
- B. Connect the gray end of DB9 cable to connector in endplate.
- C. Connect the new receiver cables to the back of the controller.

**IMPORTANT: THE YELLOW END OF THE DB9 CABLE SHOULD ALWAYS BE PLUGGED INTO THE "MAIN" CONTROLLER.**

## **SETUP OF MAIN AND FOLLOWER CONTROLLERS**

This is routine #2 in the MLS Manual. "Enter an address for controller"

You will need to do step 11 for each controller to enter the change address routine, then depending on the controller either jump to step 12 or 13.

### **22. Enter address of MLS controllers**

- A. Turn POWER OFF.
- B. Turn SWITCH #2 ON, all others OFF.
- C. Press and hold "SET LOAD TIME" button, turn POWER ON.
- D. Hold for 3 seconds, while all lights blink rapidly.
- E. Release when blinking stops
- F. Now go to 12. for Main or 13. for Follower.

### **23. To enter address of MAIN controller.**

(note that main controller should already have this address)

- A. Turn ON switches 7 and 8.
- B. Turn OFF all other switches.
- C. Press and hold "SET LOAD TIME" button for 1 second.
- D. All lights will flash and then go off.
- E. Release button to resume operation

### **24. To enter address of FOLLOWER Controller.**

- A. Turn ON switches 1, 7 and 8.
- B. Turn OFF all other switches.
- C. Press and hold "SET LOAD TIME" button for 1 second.
- D. All lights will flash and then go off.
- E. Release button to resume operation.

## 3 – General Information

---

### MLS Clear Vu Features

**VACUUM UNIT:**

The ring compressor vacuum power unit is QUIET, RELIABLE, and LONG LASTING. A single power unit supplies 8 stations, keeping costs low.

**POSITIVE OPERATION OF VALVES:**

All valves are positively operated by air cylinders. There are no weighted flaps that might not close properly. Valves close with a sliding action so "Static cling" pellets are wiped clear.

**STROBE LIGHT and audible ALARM:**

STROBE LIGHT and audible ALARM activate whenever a load cycle does not satisfy the sensor.

**STATION ALARMS:**

On total system power up, or after turning power on for a given station, the "alarm" function for that station is not active. Filling the hopper for the first time, and covering the sensor, activates the "alarm" function for that station.

After this "full hopper" initialization, the alarm will sound if the sensor is not immediately satisfied after a load cycle.

Alarms may be selectively disabled for each station.

**ALARM SILENCE BUTTON:**

The silence button silences the alarm until any new event starts it up again. The covering of the sensor of an alarming station will also silence the alarm, (unless another station is also in an alarm state).

**STATION TIMERS:**

Each receiver has a LOAD TIME associated with it. Initial default load times are 10 seconds and may be altered using the "SET LOAD TIME" button.

**SET TIMERS BUTTON:**

A TIMER button is provided as an input to the processor. During any single load time, if the button is pressed, the loading time will continue to run until the button is released. When released, the station will stop loading immediately. The time of release establishes the NEW load time for that station.

One button serves to set times for all stations.

**FILTERLESS RECEIVERS:**

Individual receivers are filterless. A central dust filter protects the blower unit. This eliminates the need to service filters on top of hoppers and places the only filter in easy reach.

**EXPANDABLE UP TO 16 RECEIVERS:**

Your controller can control up to 8 receivers. However, additional controller can be "linked" to your first controller using the Dual Controller Option, allowing up to 16 receivers to operate off one single vacuum pump.

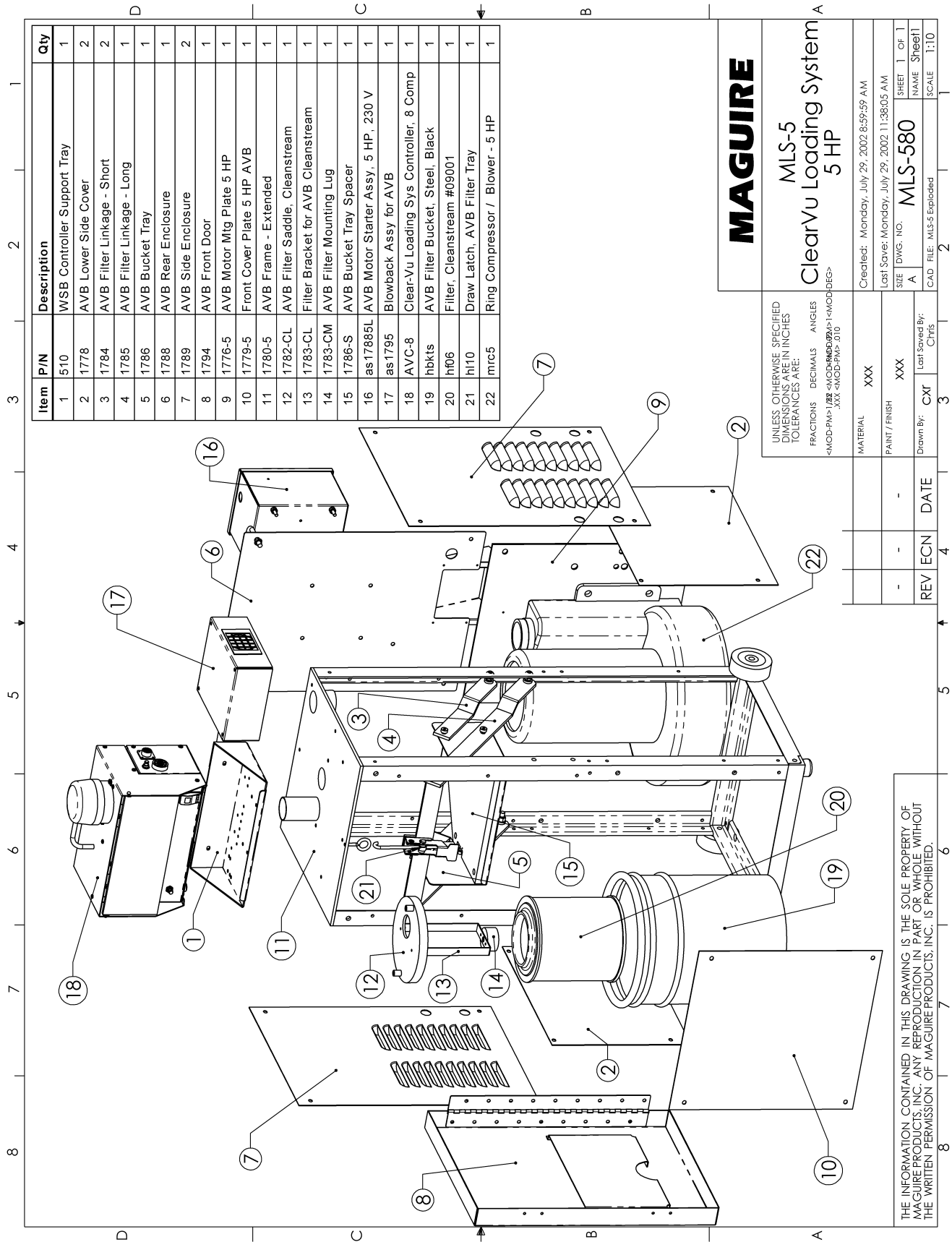

Item	P/N	Description	Qty
1	510	WSB Controller Support Tray	1
2	1778	AVB Lower Side Cover	2
3	1784	AVB Filter Linkage - Short	2
4	1785	AVB Filter Linkage - Long	1
5	1786	AVB Bucket Tray	1
6	1788	AVB Rear Enclosure	1
7	1789	AVB Side Enclosure	2
8	1794	AVB Front Door	1
9	1776-5	AVB Motor Mtg Plate 5 HP	1
10	1779-5	Front Cover Plate 5 HP AVB	1
11	1780-5	AVB Frame - Extended	1
12	1782-CL	AVB Filter Saddle, Cleanstream	1
13	1783-CL	Filter Bracket for AVB Cleanstream	1
14	1783-CM	AVB Filter Mounting Lug	1
15	1786-S	AVB Bucket Tray Spacer	1
16	as 17885L	AVB Motor Starter Assy, 5 HP, 230 V	1
17	as 1795	Blowback Assy for AVB	1
18	AVC-8	Clear-Vu Loading Sys Controller, 8 Comp	1
19	hbkts	AVB Filter Bucket, Steel, Black	1
20	ht06	Filter, Cleanstream #09001	1
21	ht10	Draw Latch, AVB Filter Tray	1
22	mrc5	Ring Compressor / Blower - 5 HP	1

**MAGUIRE**

MLS-5  
ClearVu Loading System  
5 HP

Created: Monday, July 29, 2002 8:59:59 AM  
 Last Save: Monday, July 29, 2002 11:38:05 AM  
 DWG. NO. **MLS-580**  
 SHEET 1 OF 1  
 NAME Sheet1  
 CAD FILE: MLS-5-Explosed  
 SCALE 1:10

UNLESS OTHERWISE SPECIFIED DIMENSIONS ARE IN INCHES TOLERANCES ARE:

FRACTIONS	DECIMALS	ANGLES
<MOD>P<MOD> / <MOD> <MOD>	<MOD>P<MOD> <MOD>	<MOD>D<MOD>
.XXX	.XX	.010

MATERIAL	XXX
PAIN / FINISH	XXX
Drawn By:	CXT
Last Saved By:	CTIS

REV	ECN	DATE
-	-	-

THE INFORMATION CONTAINED IN THIS DRAWING IS THE SOLE PROPERTY OF MAGUIRE PRODUCTS, INC. ANY REPRODUCTION IN PART OR WHOLE WITHOUT THE WRITTEN PERMISSION OF MAGUIRE PRODUCTS, INC. IS PROHIBITED.

# AVR-10 \_ \_ CLEAR-VU RECEIVER

Item	P/N	Description
1	as1771-2	AVR Top Casting Assy w/ 2" Material Inlet
2	as1771T2	AVR Material Inlet Assy, Ø2"
3	ncy9	Air Cylinder, 2" Stroke
4	fpe-532	Elbow Fitting, 1/8 MPT x 5/32 Press-in
5	1773	1/4" Sq. Rubber Gasket, cut to length
6	1771-RS	Connecting Rod End Support
7	1771-RSC	Support Clip
8	hl04	Draw Latch
9	snj4	1/4-20 Jam Nut
10	1772	Clear Receiver Tube - 8" OD
11	1771-R	AVR Connecting Rod
12	ehsx03	18 mm Proximity Switch
13	1770	AVR Base Casting
14	as1770-V	Slider & Clevis Assy
15	snj5	5/16-24 Jam Nut
16	sb4-08	1/4-20 x 1/2" BHCS
17	swL4	1/4" Split Lock Washer
18	1770-R	AVR Guide Rod - Slide Gate
19	fptr532	Male Run Tee, 1/8 MPT x 5/32 Pres
20	ncy29	Air Cylinder, 3" Stroke
21	fpc-532	Male Conn, 1/8 MPT x 5/32 Pres
22	as1790	AVR Solenoid Assy w/ Prox Sensor
23	nv51	Solenoid Valve 24 VDC
24	fbe2	Street Elbow 1/8 MPT x 1/8 FPT
25	fpt2-532	Swivel Tee, 1/8 MPT x 5/32 Pres

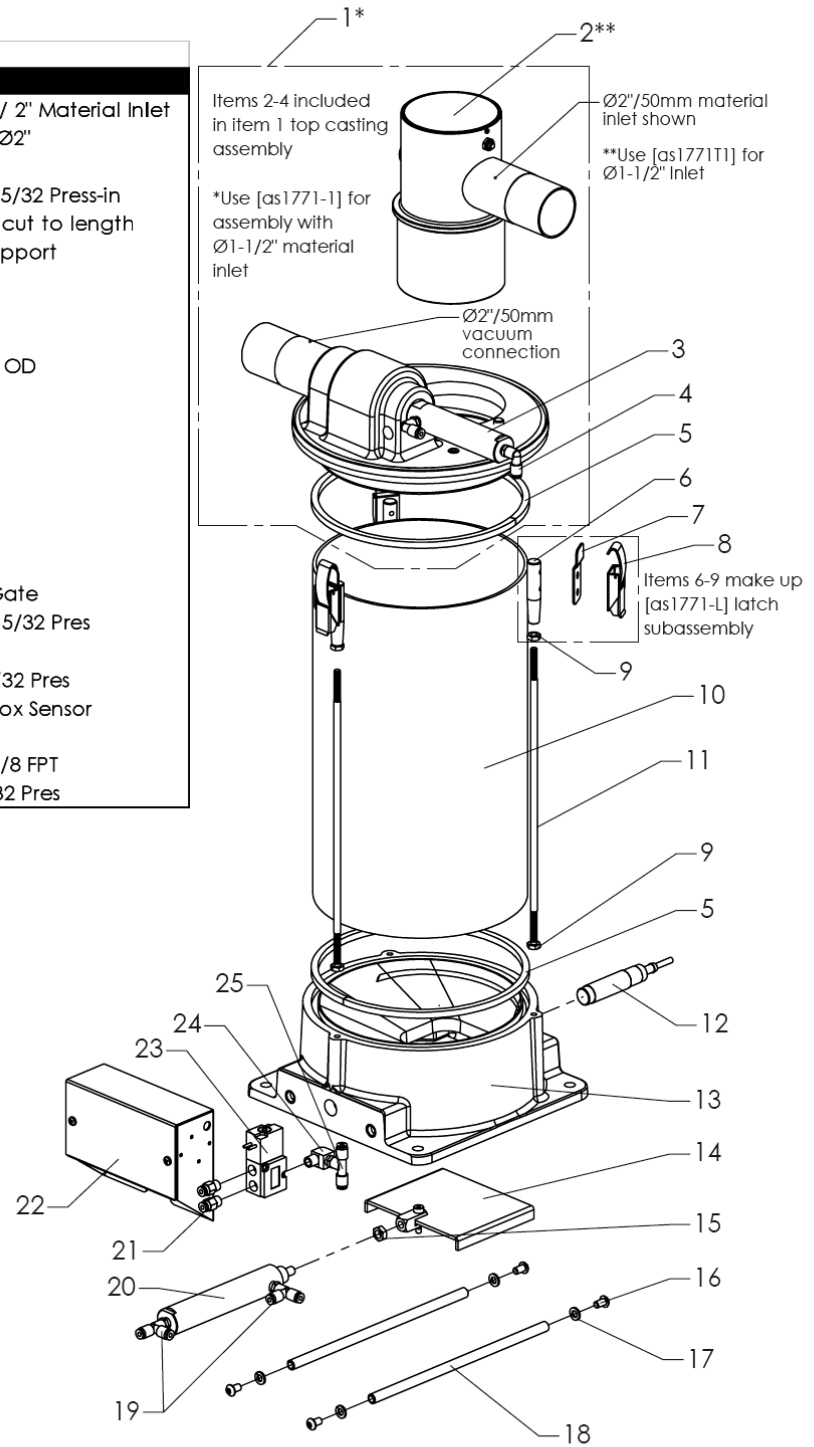

AVR-10\_Exploded\_180524

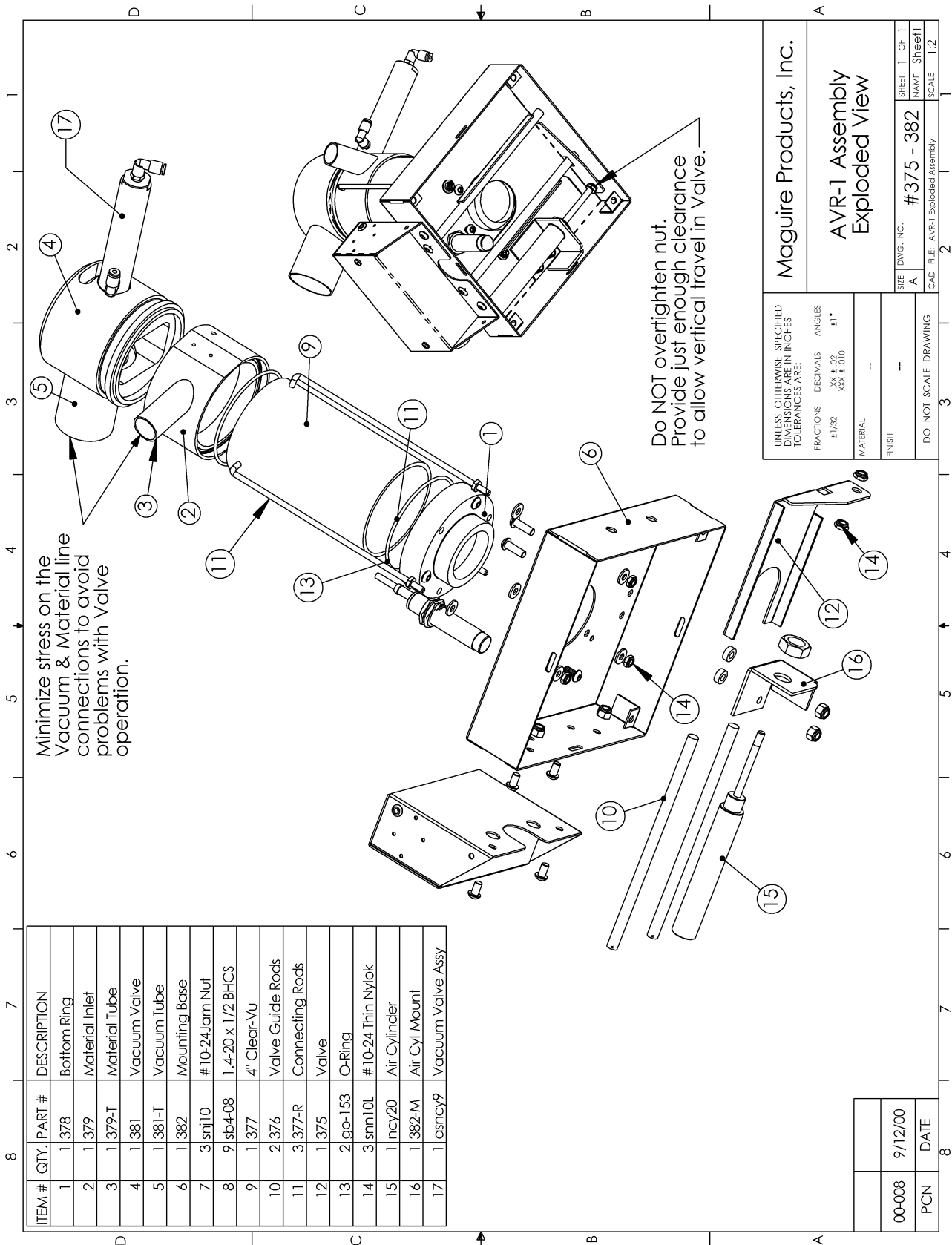

Minimize stress on the Vacuum & Material line connections to avoid problems with Valve operation.

Do NOT overtighten nut. Provide just enough clearance to allow vertical travel in Valve.

ITEM #	QTY.	PART #	DESCRIPTION
1	1	378	Bottom Ring
2	1	379	Material Inlet
3	1	379-T	Material Tube
4	1	381	Vacuum Valve
5	1	381-T	Vacuum Tube
6	1	382	Mounting Base
7	3	snj10	#10-24 Jam Nut
8	9	sb4-08	1.4-20 x 1/2 BHCS
9	1	377	4\" Clear-Vu
10	2	376	Valve Guide Rods
11	3	377-R	Connecting Rods
12	1	375	Valve
13	2	go-153	O-Ring
14	3	snm10L	#10-24 Thin Nylok
15	1	ncv20	Air Cylinder
16	1	382-M	Air Cyl Mount
17	1	asncy9	Vacuum Valve Assy

UNLESS OTHERWISE SPECIFIED DIMENSIONS ARE IN INCHES TOLERANCES ARE: FRACTIONS    DECIMALS    ANGLES $\pm 1/32$ $\pm .02$ $\pm 1^\circ$ $.XXX \pm .010$		SHEET 1 OF 1 NAME Sheet1 SCALE 1:2
MATERIAL --- FINISH ---		DO NOT SCALE DRAWING
Maguire Products, Inc. AVR-1 Assembly Exploded View		SIZE DWG. NO. #375 - 382 CAD FILE: AVR-1 Exploded Assembly

00-008	9/12/00
PCN	DATE

## Technical Support and Contact Information

**Maguire Products Inc.**  
11 Crozerville Road  
Aston, PA 19014  
Tel: 610.459.4300  
Fax: 610.459.2700  
Email: [info@maguire.com](mailto:info@maguire.com)  
Web: [www.maguire.com](http://www.maguire.com)

**Maguire Europe**  
Tame Park  
Tamworth  
Staffordshire  
B775DY  
UK  
Tel: + 44 1827 265 850  
Fax: + 44 1827 265 855  
Email: [info@maguire-europe.com](mailto:info@maguire-europe.com)

**Maguire Products Asia PTE LTD**  
Main Office  
15 Changi North Street 1  
#01-15, I-Lofts  
Singapore 498765  
Tel: 65 6848-7117  
Fax: 65 6542-8577  
E-mail: [magasia@maguire-products.com.sg](mailto:magasia@maguire-products.com.sg)